



LIVINGSTATION™

HDTV LCD Projection Television LS47P2 • LS57P2

User's Guide

Copyright Notice

All rights reserved. No part of this publication may be reproduced, stored in a retrieval system, or transmitted in any form or by any means, electronic, mechanical, photocopying, recording, or otherwise, without the prior written permission of Seiko Epson Corporation. The information contained herein is designed only for use with this Epson product. Epson is not responsible for any use of this information as applied to other equipment.

Neither Seiko Epson Corporation nor its affiliates shall be liable to the purchaser of this product or third parties for damages, losses, costs, or expenses incurred by purchaser or third parties as a result of: accident, misuse, or abuse of this product or unauthorized modifications, repairs, or alterations to this product, or (excluding the U.S.) failure to strictly comply with Seiko Epson Corporation's operating and maintenance instructions.

Seiko Epson Corporation shall not be liable for any damages or problems arising from the use of any options or any consumable products other than those designated as Original Epson Products or Epson Approved Products by Seiko Epson Corporation.

Responsible Use of Copyrighted Materials

Digital cameras, scanners, and printers, like conventional photocopiers and cameras, can be misused by improper copying or printing of copyrighted material. While some countries' laws permit limited copying of copyrighted material in certain circumstances, those circumstances may not be as broad as some people assume. Epson encourages each user to be responsible and respectful of the copyright laws when using digital cameras, scanners, and printers.

Trademarks

Epson is a registered trademark and Livingstation is a trademark of Seiko Epson Corporation.

Epson Connection and Epson Store are service marks, and Epson PrivateLine is a registered trademark, of Epson America, Inc.

Pixelworks, DNX, and the DNX Pixelworks logo are trademarks of Pixelworks, Inc.

Portions of this software are based in part on the work of the independent JPEG Group.

General Notice: Other product names used herein are for identification purposes only and may be trademarks of their respective owners. Epson disclaims any and all rights in those marks.

The ENERGY STAR emblem does not represent EPA endorsement of any product or service.



Contents

Setting Up the TV

Selecting a Location	7
Important Safety Instructions	7
Outdoor Antenna Installation and Grounding	10
Suggested Supports or Stands	11
Installing the Set-Top Shelf	12
Securing the TV	13
Connecting the HDTV Tuner	14
Connecting the CD-R/RW Drive	15
Connecting Other Equipment	16
Antenna or Direct Cable TV Connection	17
Cable Box Connections	18
Satellite Receiver Connection	20
DVD Player With a DVI Connection	21
DVD Player With Component Video Connection	22
DVD Player With an S-Video Connection	23
VCR Connection	24
VCR and Cable Service (Without Cable Box) Connection	25
VCR and Cable Box Connection	26
VCR and Satellite Receiver Connection	27
Stereo Amplifier Connection	29
PC or Game Console Connection	30
Camcorder, Digital Camera, or Other Portable Video Connection	31
Other Optional Device Connections	32
Preparing the Remote Control	33
Inserting the Batteries	33
Operating the Remote Control	34
Remote Control Information	34
Controlling the HDTV Tuner With the Remote Control	35
Controlling Other Equipment With the Remote Control	36
Programming the Remote Control	36
Using the Programmed Remote Control With Your Other Equipment	36
Remote Control Programming Codes	37
Plugging In and Turning On the TV	41
Changing the Language of the Menus and Screen Text	42
Skipping Unused Input Sources	43
Labelling Input Sources	44
Selecting a Predefined Label	45
Creating a Custom Label	45
Deleting a Label	45
Turning Off the TV	46

Setting Up and Controlling Channels

Setting Up Your TV Channels	47
Automatically Setting Up Your Channels	47
Manually Adding or Skipping Channels	49
Selecting Channels	50
Setting Up Favorite Channels	50

Labelling TV Channels	51
Selecting a Predefined Label	52
Creating a Custom Label	52
Deleting a Label	52
Setting Up Parental Controls	53
Creating a Password	53
Blocking Programs Using V-Chip	55
Blocking Channels and Input Sources	59
Accessing Blocked Programs, Movies, Channels, and Input Sources	61

Adjusting the Picture and Sound

Adjusting the Picture Quality	63
Changing the Color Mode	64
Adjusting the Brightness, Contrast, Sharpness, Saturation, Tint, and Black Level	64
Adjusting the Color Temperature	65
Adjusting the Screen Position	65
Switching the Component Video Image Quality Setting	65
Selecting the Aspect Ratio	66
Selecting the Default Aspect Ratio	67
Adjusting the Sound	68

Using TV Features

Printing What You See on the Screen	69
Changing the Capture Settings	71
Using Picture-Outside-Picture (POP)	71
Using Channel Zapping	73
Turning Off the ANT 2 Port	73
Zapping Channels	74
Turning On Closed Caption Display	75
Selecting an Alternate Audio Track or Language	75
Automatically Shutting Off the TV	76
Putting the TV Into Sleep Mode	76
Setting Up Auto Shutdown	76

Viewing, Printing, and Saving Photos

Viewing Photos on a Digital Photo Card or CD	77
Compatible Photos and File Structure (Photo Card)	77
Inserting a Photo Card	78
Compatible Photos and File Structure (CD)	80
Inserting a CD	80
Enlarging and Rotating Photos	83
Viewing a Slide Show	84
Printing Photos	86
Loading Paper	86
Selecting a Photo and Printing It	89
Monitoring or Cancelling Your Print Jobs	91
Saving Photos to CD	92
Inserting a CD-R/RW	93
Writing All Photos to a CD-R/RW	93

Caring For the TV

Cleaning the TV	95
Cleaning the Air Filter	95
Replacing the TV Projection Lamp	97
Lamp Replacement Precautions	98
Removing and Installing the Lamp	98
Replacing the Printer Ink Cassette	101
Sliding Out the Printer	101
Removing and Replacing the Ink Cassette	103
Sliding the Printer Back In	106
Moving or Transporting the TV	107

Solving Problems

Responding to Screen Error Messages	109
Responding to TV Panel Light Indicators	110
Basic Operation Problems	112
Picture Problems	112
Sound Problems	113
TV Reception or Operation Problems	114
Remote Control Problems	114
Problems Viewing Photos from Cards or Discs	115
Printing Problems	115
Clearing a Paper Jam From the Back of the Printer	117
Problems Saving Photos to a CD-R/RW	121
Where to Get Help	121
Telephone Support Services	121

Specifications

General	123
Screen and Display	123
Mechanical	123
Electrical	123
Environmental	124
Interfaces	124
Printer	125
Options	125
Safety	125
EMI	125

Notices

Epson America, Inc., Limited Warranty	127
ENERGY STAR Compliance	128
Note on Closed Captioning	128
Note on TV Use	128
FCC Compliance Statement	129

Index

.	131
-----------	-----

Setting Up the TV

Follow the steps in these sections to prepare a spot for your TV, set it up, connect it, turn it on, and prepare it for viewing:

- “Selecting a Location” below
- “Installing the Set-Top Shelf” on page 12
- “Connecting the HDTV Tuner” on page 14
- “Connecting the CD-R/RW Drive” on page 15
- “Connecting Other Equipment” on page 16
- “Preparing the Remote Control” on page 33
- “Controlling the HDTV Tuner With the Remote Control” on page 35
- “Controlling Other Equipment With the Remote Control” on page 36
- “Plugging In and Turning On the TV” on page 41
- “Skipping Unused Input Sources” on page 43
- “Labelling Input Sources” on page 44
- “Turning Off the TV” on page 46

Selecting a Location

Select a suitable location for your TV and follow all of its safety instructions to ensure it operates effectively and safely, as described in these sections:

- “Important Safety Instructions” below
- “Outdoor Antenna Installation and Grounding” on page 10
- “Suggested Supports or Stands” on page 11

Important Safety Instructions

Selecting a Suitable Environment for the TV

- The TV is very heavy. Two people are required to lift or move the TV to avoid injury.
- Do not place the TV on an unstable or tilted cart, stand, or table. Place the TV on the center of the stand, making sure it is fully supported on all sides.
- Do not place the TV near water or sources of heat.
- Do not place the TV in direct sunlight, such as in front of a window.

Note

To CATV system installers:

Article 820-40 of the NEC provides guidelines for proper grounding and specifies that the cable ground shall be connected to the grounding system of the building, as close to the point of cable entry as practical.

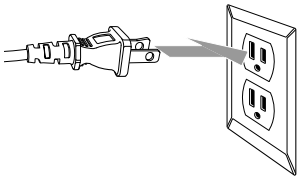

- Do not place the TV in an area subject to vibration.
- Do not place the TV or the remote control on top of or near heat-producing equipment or in a hot location.
- Do not operate the TV in an area with high temperatures or humidity, or where large amounts of dust are present.
- Leave at least 12 inches (30 cm) of room around the vents on the sides of the TV and do not block the vents. They provide ventilation and prevent the TV from overheating.
- Do not use the TV in temperatures outside of the range of 41 to 95 °F (5 to 35 °C).
- Do not store the TV in temperatures outside the range of 14 to 140 °F (-10 to 60 °C).
- If you place the TV in a permanent installation near a wall, secure the TV to the wall using screws and steel wire connected to the two screw holes on the top rear of the TV.

Plugging the TV Into an Electrical Outlet

- Use only the type of power source indicated on the TV. If you are not sure of the power available, consult your dealer or power company.
- Place the TV near a wall outlet where the power cord can be easily unplugged.
- Do not overload wall outlets, extension cords, or integral convenience receptacles. This can cause fire or electric shock.
- Do not defeat the safety purpose of the polarized plug (two blades, with one wider than the other). Connect the plug only to a compatible outlet where you can fully insert the plug to prevent exposure of the plug blades. If you are unable to insert the plug fully, try reversing the plug. If the provided plug does not fit your outlet, consult an electrician for replacement of the outlet.
- Do not place the TV where the power cord can be walked on. This may result in fraying or damage to the plug.
- Take the following precautions when plugging in the TV. Failure to comply with these precautions could result in sparks, fire, or electric shock: Do not insert the plug into an outlet with dust present. Do not insert the plug with wet hands. Insert the plug firmly into the outlet.
- Unplug the TV during lightning storms or when it will not be used for extended periods.
- Unplug the TV from the wall outlet before cleaning.
- Pull on the plug housing to unplug the power cord; do not pull on the cord.

Operating the TV Safely

- Except as specifically explained in this *User's Guide*, do not attempt to service this product yourself. Refer all servicing to qualified personnel. Opening or removing covers may expose you to dangerous voltages or other hazards.
- Unplug the TV from the wall outlet and refer servicing to qualified personnel under the following conditions:
 - When the power cord is damaged or frayed, or if it becomes hot.
 - When liquid has been spilled into the TV or if it has been exposed to rain or water.
 - If the TV does not operate normally when you follow the operating instructions, or if it exhibits a distinct change in performance, indicating a need for service.
 - If the TV has been dropped or the housing has been damaged.
- Do not stand on the TV or place heavy objects on top of it.
- Do not block the slots and openings in the TV case.
- Never push objects of any kind through the cabinet slots.
- Never insert an object other than a digital photo card in the card slots, or an object other than paper or an ink cassette into the printer. Do not use sharp tools to remove a card from a slot or you may damage the slot and card.
- Use only the ink cassette and paper specified for use in the Epson Livingstation printer (part number V13H151010).
- Never spill liquid of any kind into the TV.
- Do not move or lift the TV by moving or lifting the stand or table supporting it; the TV may fall and cause injury.

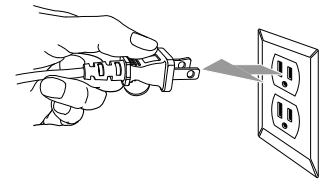

Replacing the Projection Lamp Safely

- Never touch the projection lamp immediately after turning off the TV or you could be burned. Wait at least 30 minutes after turning off the TV to let the lamp cool down completely.
- If the lamp has broken, handle the shards carefully to avoid injury.
- The used lamp contains mercury. Please consult your state and local regulations regarding disposal or recycling. Do not put the lamp in the trash.
- Install the new lamp securely to avoid an electrical short or other damage. Insert the lamp as described on page 97, pushing it all the way into its slot. Tighten the screws to lock the lamp securely into place or the lamp will not come on.
- Do not touch the glass on the lamp with your bare hands. This can shorten the lamp life and obscure the projected image. Use a cloth or glove to handle the new lamp.
- Do not drop the replacement lamp or bump it against any surface; the lamp could be permanently damaged.

Outdoor Antenna Installation and Grounding

- It is best to have a professional technician install an antenna on the roof of a structure. If you install an antenna yourself, be careful to avoid serious injury.
- If an outside antenna is connected through other equipment, be sure the antenna system is grounded so as to provide protection against voltage surges and built-up static charges. In the U.S.A., section 810 of the National Electrical Code, ANSI/NFPA 70, provides information on proper grounding of the mast and supporting structure, grounding of the lead-in wire to an antenna-discharge unit, size of grounding conductors, location of antenna-discharge unit, connection to grounding electrode, and requirements for the grounding electrode.

Example of Antenna Grounding in National Electrical Code Instructions

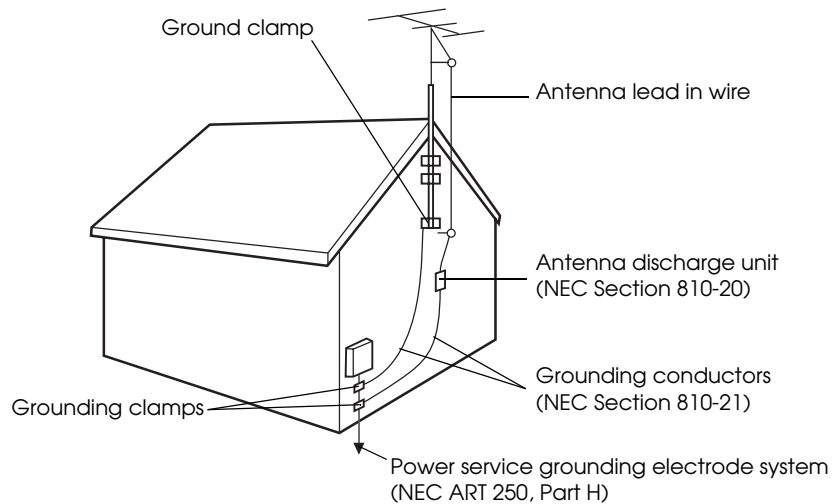

- An outdoor antenna system should not be located in the vicinity of overhead power lines/ electric lights or power circuits, or where it can fall onto such power lines or circuits. When installing an outdoor antenna system, extreme care should be taken to keep it from touching such power lines or circuits as contact with them might be fatal.
- For added protection during a lightning storm, or when it is left unattended and unused for long periods of time, unplug the TV from the wall outlet and disconnect the antenna. This will prevent damage due to lightning and power-line surges.

Suggested Supports or Stands

You can use an optional Epson TV stand to support your TV. Order part number V12H003R03 (for the LS47P2) or V12H003R02 (for the LS57P2) from your dealer.

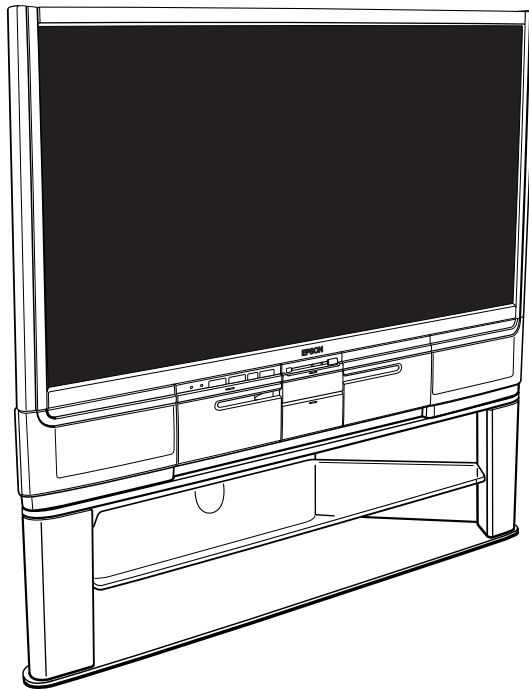

If you use your own stand, make sure it can securely support the TV as follows:

Specification	LS47P2	LS57P2
Width of the base (minimum)	47 inches (119 cm)	56 inches (142 cm)
Depth of the base (minimum)	16 inches (41 cm)	18 inches (46 cm)
Weight capacity (minimum)	331 lb (159.0 kg)	331 lb (159.0 kg)

Make sure you place the stand in a location that allows you access to the back of the TV and provides at least 12 inches (30 cm) of room for ventilation at the sides.

Installing the Set-Top Shelf

The set-top shelf provides a convenient support for a center surround sound speaker or other component on top of the TV. The shelf can hold up to 11 lb (5 kg).

Caution

Don't fold the shelf backwards on its hinge or it may break.

- 1 Fold the shelf into an upside-down L-shape with the shorter end on top.

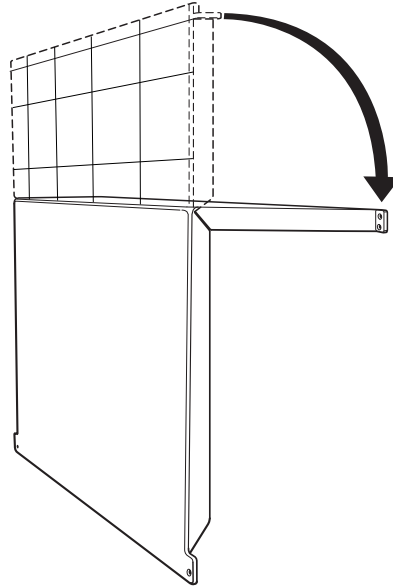

- 2 Align the holes in the shelf with the holes on the back of the TV.

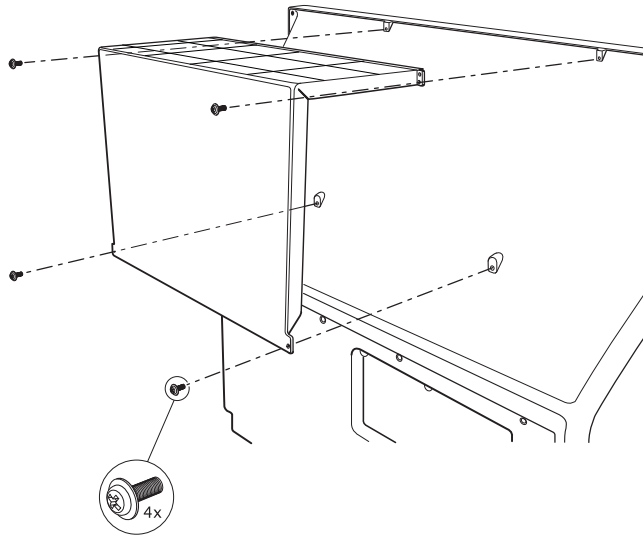

- 3 Using a Phillips-head screwdriver, secure the shelf to the TV with the four screws that came with it. Tighten the screws.

Securing the TV

You may want to secure the TV to a wall or other support so it stays upright on its stand during an earthquake or other situation. Use wires and screws connected to the outer pair of holes on the top of the TV to secure the TV to the wall or other support.

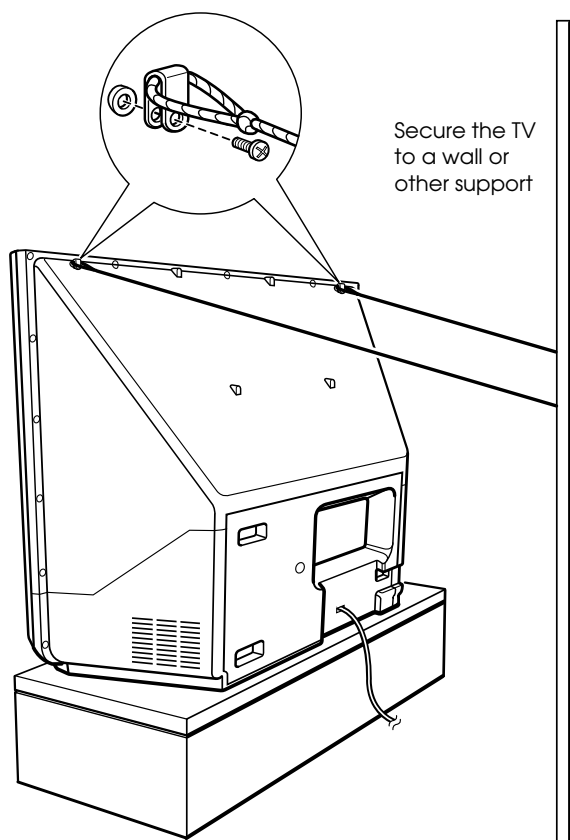

Connecting the HDTV Tuner

If your TV included an HDTV tuner, follow these instructions to connect it.

- 1 Turn off and unplug your TV and tuner.
- 2 Slide the OUTPUT SWITCH on the back of the tuner to YPbPr.
- 3 Connect your antenna's wall jack to the RF IN jack on the tuner using a standard coaxial antenna cable.
- 4 Connect one end of the component video cable (included with your TV) to the Y (green), PB (blue), and PR (red) connectors on the back of the TV, as shown below. Be sure to match the colors of the cables to the colors of the connectors.

Note

For more information on connecting an antenna, see the tuner *User's Guide*.

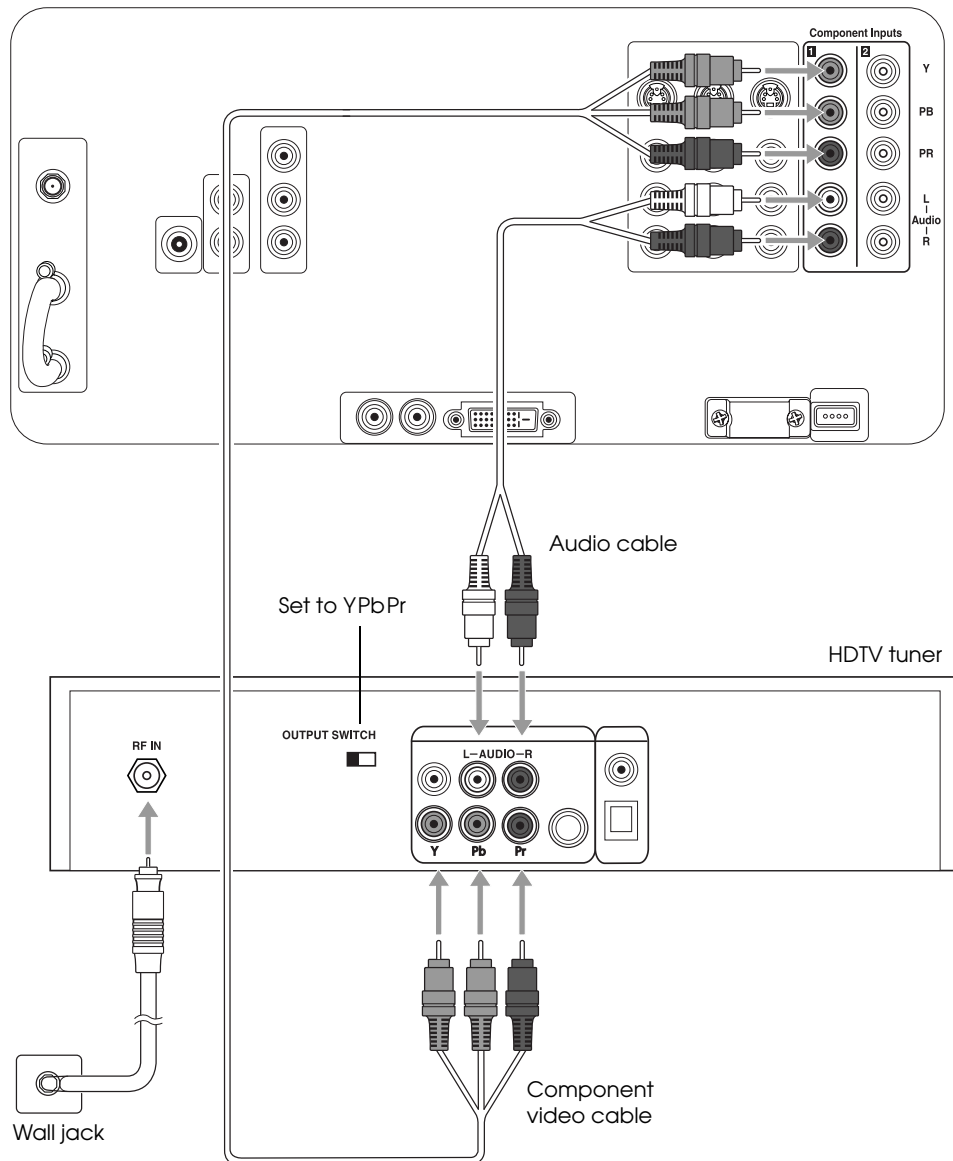

- 5 Connect the other end of the cable to the Y, Pb, and Pr connectors on the tuner.
- 6 Connect one end of the included RCA-style audio cable (with red/white connectors) to the L-Audio-R connectors on the back of the TV.

- 7 Connect the other end of the cable to the L-Audio-R connectors on the tuner.
- 8 Plug the TV and tuner into an electrical outlet.
- 9 See the *User's Guide* included with the tuner for instructions on setting up channels, entering the date and time, and making other basic settings.

Note

To use the TV remote control to operate the tuner, see page 35. For more information on using the tuner, see the *User's Guide* that came with it.

Connecting the CD-R/RW Drive

Follow these instructions to connect the CD-R/RW drive included with your TV.

- 1 Connect the square end of a USB cable to the USB port on your external CD-R/RW drive.
- 2 Connect the flat end of the USB cable to the EXT. I/F connector on the back of the TV.

Note

If you purchased an optional Epson TV stand, a mounting bracket is included for the drive. You may want to attach the drive to the stand before connecting its cables.

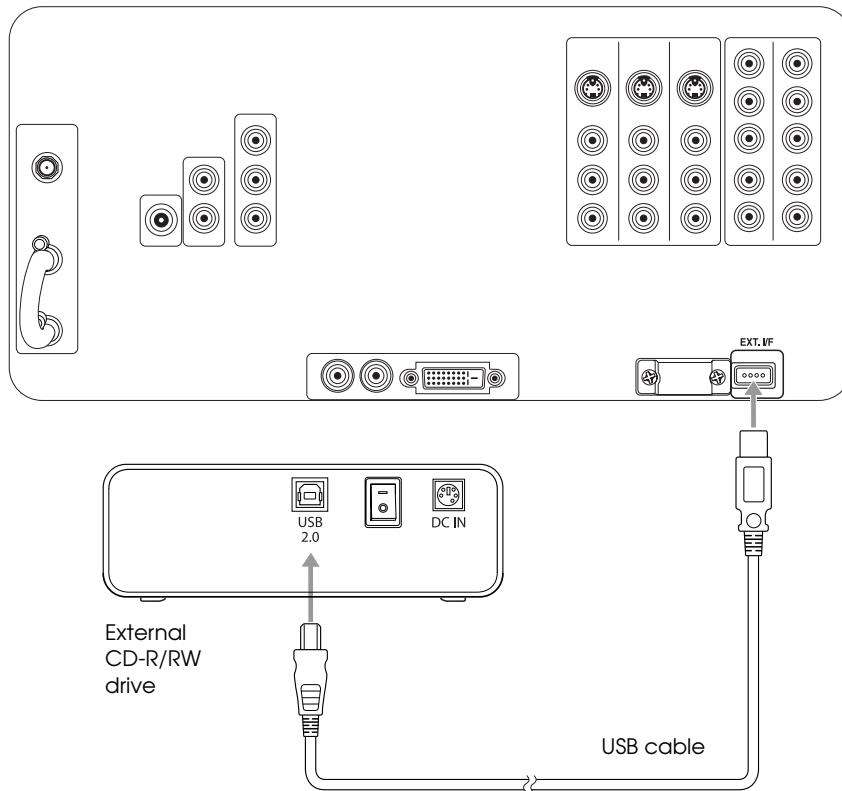

Note

The connectors on your CD-R/RW drive may be in different positions than shown.

- 3 Plug the power cord that came with the CD-R/RW into the drive's power supply, then connect the cords to the drive and an electrical outlet.
- 4 Turn on the CD-R/RW drive by flipping the power switch in back.

Note

For a description of all the available connectors on the front and back panels, see the inside back cover of this book.

Connecting Other Equipment

You can connect the TV to a variety of equipment. Follow the steps in the applicable sections below, depending on the equipment you're connecting and the type of connector or service you're using.

- “Antenna or Direct Cable TV Connection” on page 17
- “Cable Box Connections” on page 18
- “Satellite Receiver Connection” on page 20
- “DVD Player With a DVI Connection” on page 21
- “DVD Player With Component Video Connection” on page 22
- “DVD Player With an S-Video Connection” on page 23
- “VCR Connection” on page 24
- “VCR and Cable Service (Without Cable Box) Connection” on page 25
- “VCR and Cable Box Connection” on page 26
- “VCR and Satellite Receiver Connection” on page 27
- “Stereo Amplifier Connection” on page 29
- “PC or Game Console Connection” on page 30
- “Camcorder, Digital Camera, or Other Portable Video Connection” on page 31
- “Other Optional Device Connections” on page 32

Antenna or Direct Cable TV Connection

Connect the TV to an outside antenna or to your cable system using a 75-ohm coaxial cable.

Connect the cable coming into the house to the ANT 1 connector on the back of the TV.

If your coaxial cable has a screw-type connector on the end, secure it by turning the end clockwise.

Wall jack

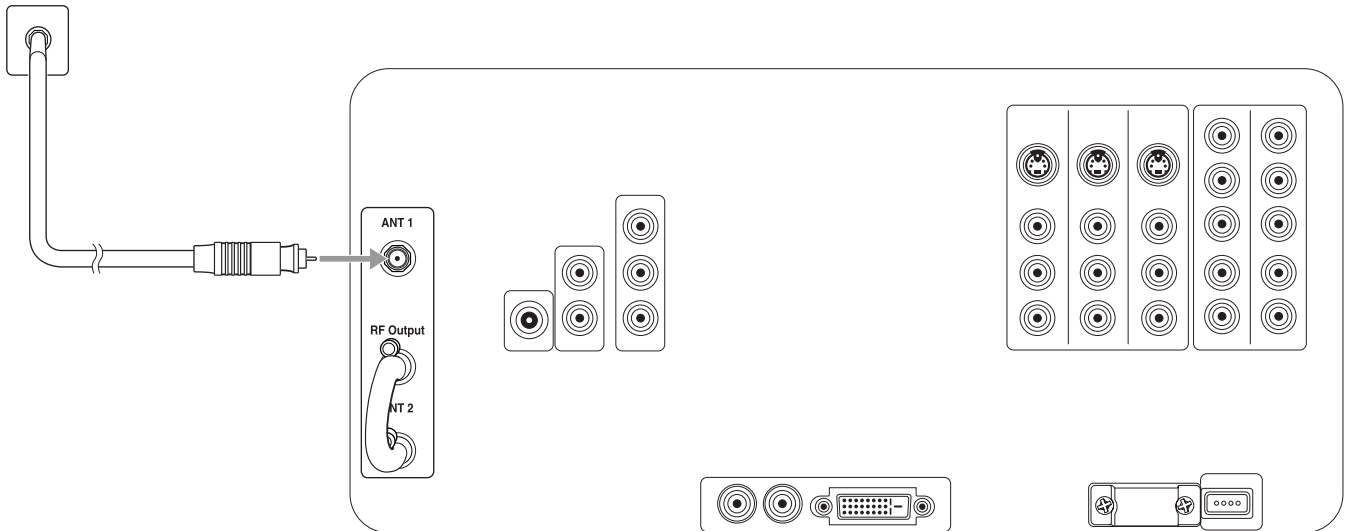

If you'll also be attaching a VCR to the TV, you need to use a different connection method so you can record TV programs. See "VCR and Cable Service (Without Cable Box) Connection" on page 25.

Note

If you have an older home, you may have a 300-ohm twin lead cable. If so, you also need an antenna connector or U/V splitter to connect it to your TV. Keep the twin lead cable as far away from your TV as possible to reduce the radio noise that may cause signal problems.

Note

Before connecting a cable box to the TV, be sure to read any instructions that came with the cable box.

Cable Box Connections

The connection method differs, depending on the type of cable box you have. Your cable box may unscramble signals for all of your channels or it may unscramble only some of them.

If you'll also be attaching a VCR to the TV, you need to use a different connection method so you can record TV programs. See "VCR and Cable Box Connection" on page 26.

Cable Box Unscrambles All Channels

If your cable box unscrambles signals for all of your channels, connect it as follows:

- 1 Connect the cable coming into the house to the IN connector on the cable box.
- 2 Connect one end of a coaxial cable to the OUT connector on the cable box.
- 3 Connect the other end of the coaxial cable to the ANT 1 connector on the back of the TV.

If your coaxial cable has a screw-type connector on the end, secure it by turning the end clockwise.

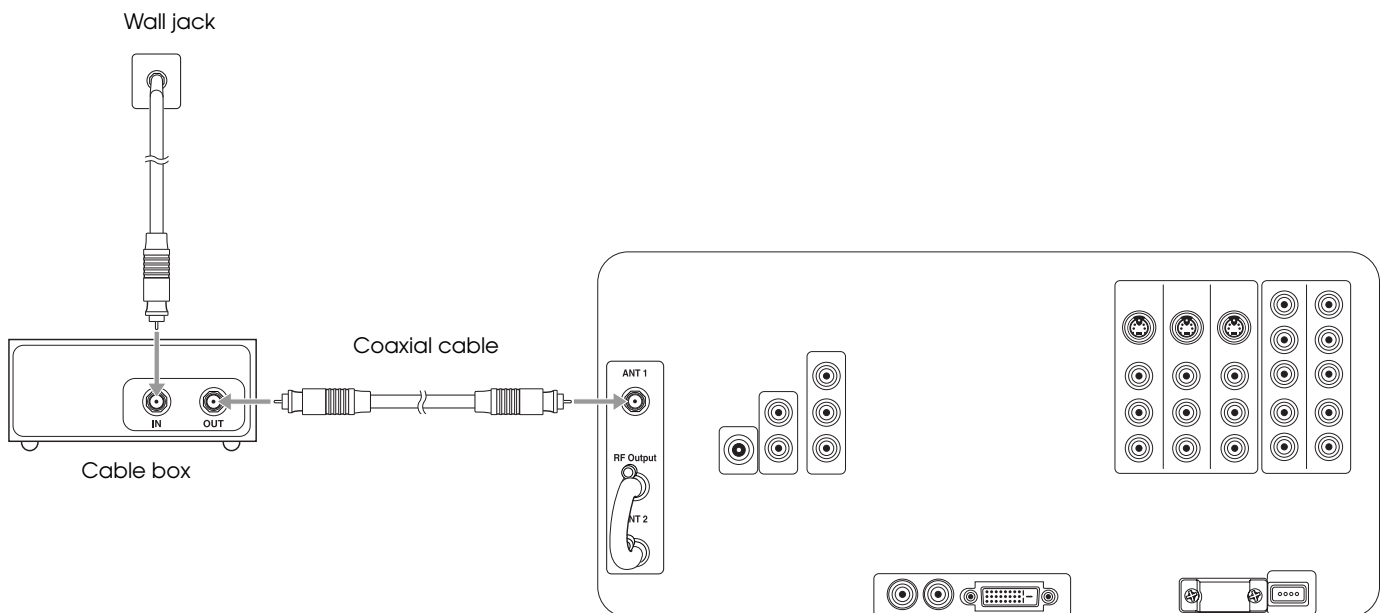

Cable Box Unscrambles Only Some of Your Channels

If your cable box unscrambles signals for only some of your channels, connect it as follows:

- 1 Connect the cable coming into the house to the ANT 1 connector on the back of the TV.
- 2 Remove the jumper cable connected to both the RF Output and ANT 2 connectors on the back of the TV. Retain the cable.
- 3 Connect one end of a coaxial cable to the RF Output connector on the back of the TV.
- 4 Connect the other end of the coaxial cable to the IN connector on the cable box.

If your coaxial cable has a screw-type connector on the end, secure it by turning the end clockwise.

- 5 Connect another coaxial cable to the OUT connector on the cable box.
- 6 Connect the other end of the coaxial cable to the ANT 2 connector on the back of the TV.
- 7 Be sure to turn on use of the TV's ANT 2 port, as described on page 47.

Note

Be sure to retain the jumper cable in case you change your TV connections later. You'll need to connect it again in certain connection schemes to provide the channel zapping feature.

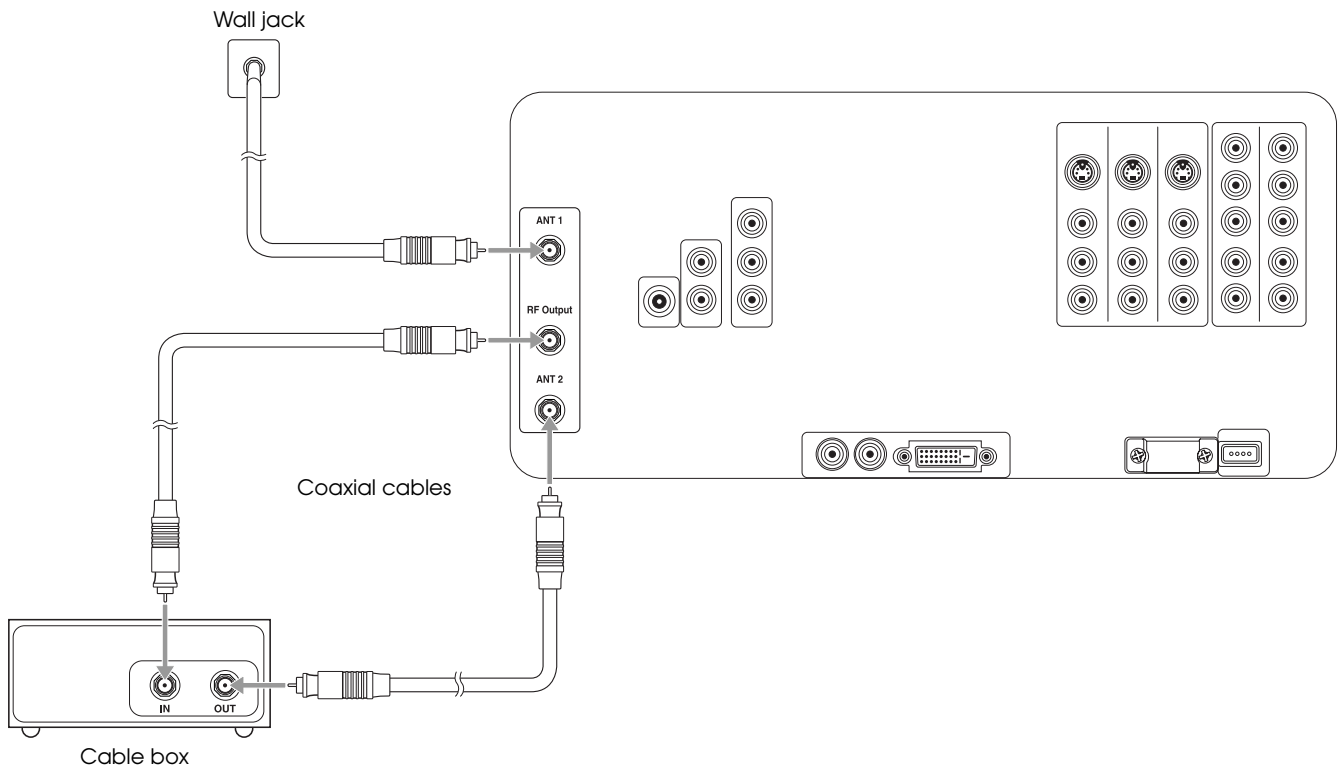

Satellite Receiver Connection

If you'll also be attaching a VCR to the TV, you need to use a different connection method so you can record TV programs. See "VCR and Satellite Receiver Connection" on page 27.

Note

If your satellite receiver doesn't have an S-video connector, you can connect a video cable (yellow) to the Video connectors instead of the S-video cable using these instructions.

It's best to connect your satellite receiver to the S-Video connectors on the back of the TV to free up the S-Video connector on the front to connect a camcorder.

- 1 Turn off and unplug your TV and your satellite receiver.
- 2 Connect the satellite antenna cable coming into your house to the **Satellite In** connector on your satellite receiver.
- 3 Connect one end of an S-video cable to one of the **S-Video** connectors on the back of the TV or to the one on the front of the TV beneath the connector cover.

(If your satellite receiver uses a DVI connection, connect a DVI cable instead, as shown on page 21. If it uses a component video connection, connect it as shown on page 22.)
- 4 Connect the other end of the S-video cable to the **S-Video** connector on your satellite receiver.
- 5 Connect one end of a standard, red/white audio cable to the corresponding **Video Inputs R and L Audio** connectors on the back or front of the TV.
- 6 Connect the other end of the audio cable to the **R and L Audio Line Out** connectors on your satellite receiver.

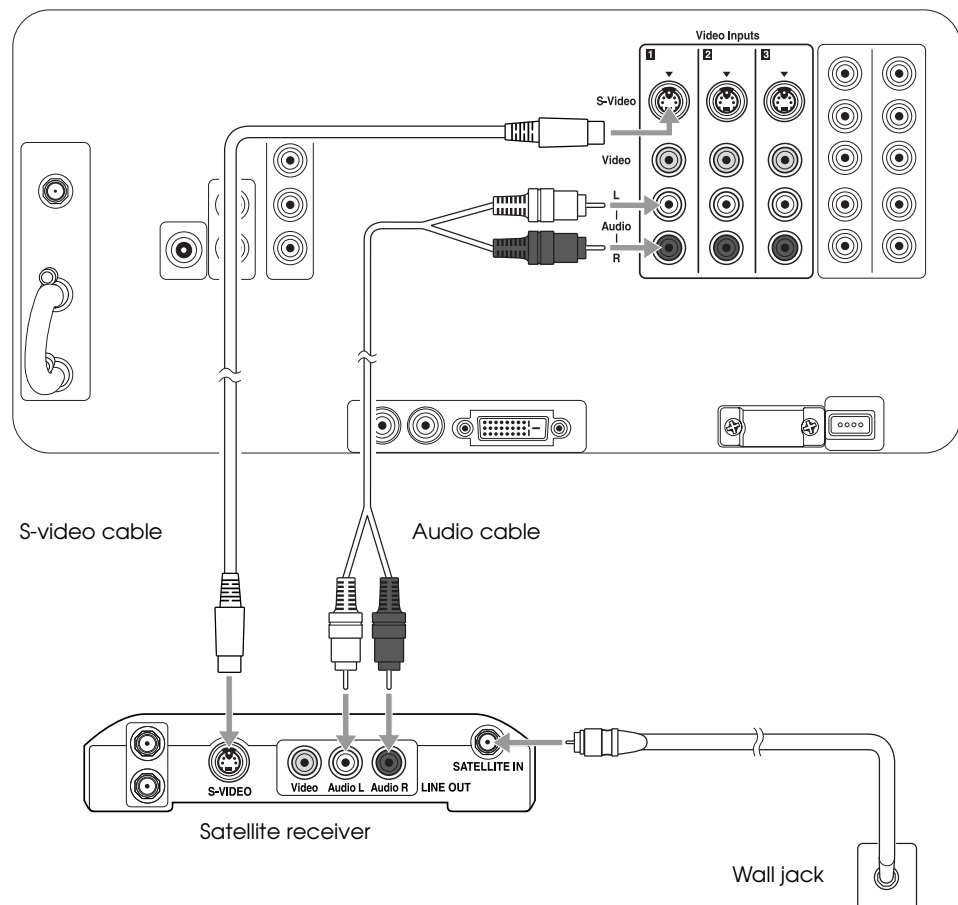

- 7 Plug your TV and satellite receiver back into their electrical outlets.

DVD Player With a DVI Connection

- 1 Turn off and unplug your TV and your DVD player.
- 2 Connect one end of a DVI-HDTV cable to the DVI-HDTV Input connector on the back of the TV.
- 3 Connect the other end of the DVI-HDTV cable to the DVI-HDTV OUT connector on your DVD player.
- 4 Connect one end of a standard, red/white audio cable to the DVI-HDTV Input R and L Audio connectors on the back of the TV.
- 5 Connect the other end of the audio cable to the R and L Audio Out connectors on your DVD player.

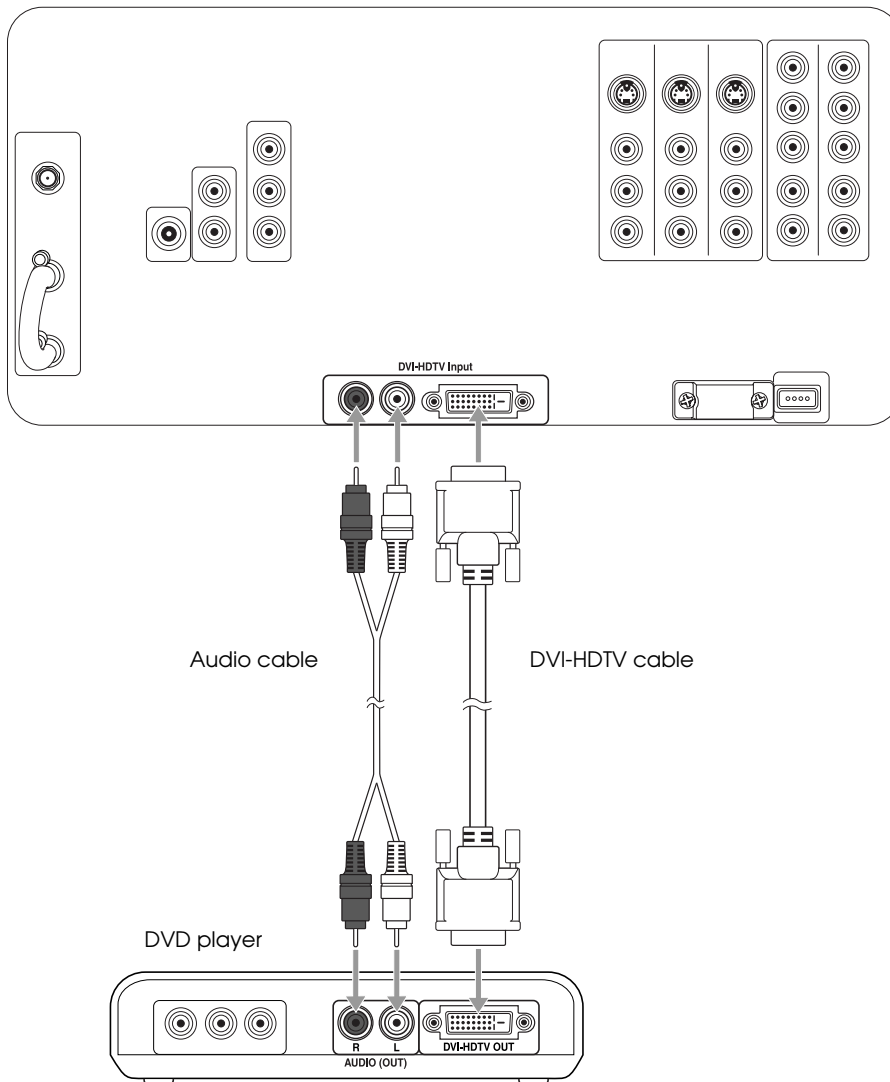

- 6 Plug your TV and DVD player back into their electrical outlets.

Note

If you have any trouble switching to the DVI input source, make sure you didn't turn off the Use of DVI Input setting. See page 43 for details.

Note

The connectors may be labeled Y, B-Y, R-Y, or Y, Cb, Cr, or Y, Pb, Pr on your DVD player, so just match the connector colors.

DVD Player With Component Video Connection

- 1 Connect one end of the component video cable to any available set of Y (green), PB (blue), and PR (red) connectors on the back of the TV.
- 2 Connect the other end of the component video cable to the corresponding color Component Video Out connectors on your DVD player.
- 3 Connect one end of a standard, red/white audio cable to the corresponding Component Input R and L Audio connectors on the back of the TV.
- 4 Connect the other end of the audio cable to the R and L Audio Line Out connectors on your DVD player.

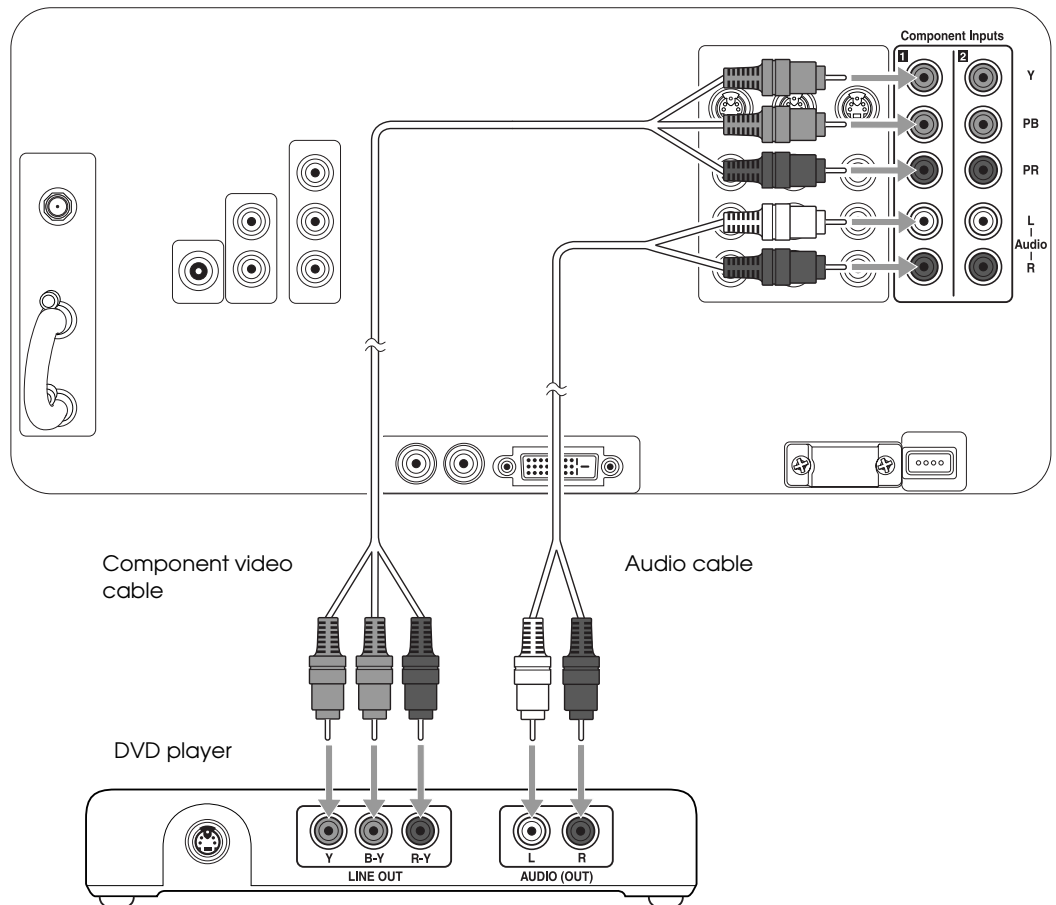

DVD Player With an S-Video Connection

- 1 Connect one end of an S-video cable to one of the S-Video connectors on the back of the TV or to the one on the front of the TV beneath the connector cover.
- 2 Connect the other end of the S-video cable to the S-Video connector on your DVD player.
- 3 Connect one end of a standard, red/white audio cable to the corresponding Video Inputs R and L Audio connectors on the back or front of the TV.
- 4 Connect the other end of the audio cable to the R and L Audio Line Out connectors on your DVD player.

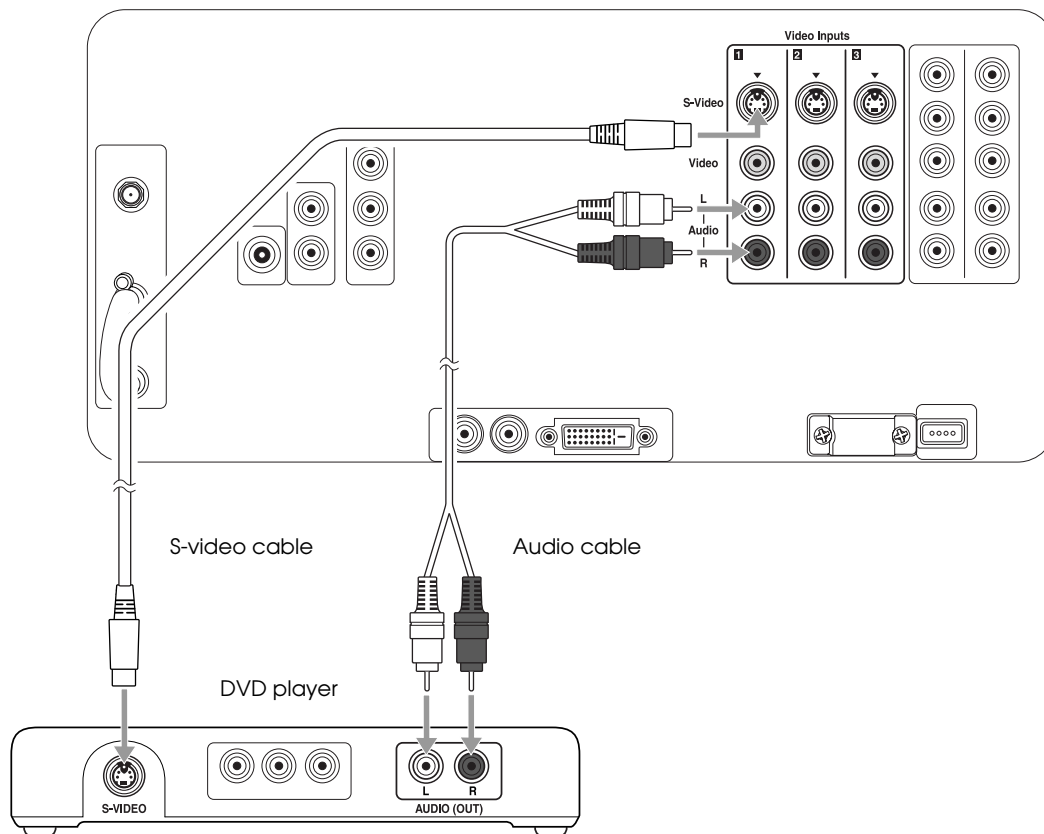

Note

If your DVD player doesn't have an S-video connector, you can connect a video cable (yellow) to the Video connectors instead of the S-video cable using these instructions.

It's best to connect your DVD player to the S-video connectors on the back of the TV to free up the S-video connector on the front to connect a camcorder.

VCR Connection

Follow these steps to connect a VCR by itself.

If you're connecting a cable, cable box, or satellite receiver along with the VCR, see the instructions in the sections following this one instead.

Note

If your VCR doesn't have an S-video connector, you can connect a video cable (yellow) to the Video connectors instead of the S-video cable using these instructions.

It's best to connect your VCR to the S-Video connectors on the back of the TV to free up the S-Video connector on the front to connect a camcorder.

- 1 Connect one end of an S-video cable to one of the S-Video connectors on the back of the TV or to the one on the front of the TV beneath the connector cover.
- 2 Connect the other end of the S-video cable to the S-Video connector on your VCR.
- 3 Connect one end of a standard, red/white audio cable to the corresponding Video Inputs R and L Audio connectors on the back or front of the TV.
- 4 Connect the other end of the audio cable to the R and L Audio Line Out connectors on your VCR.

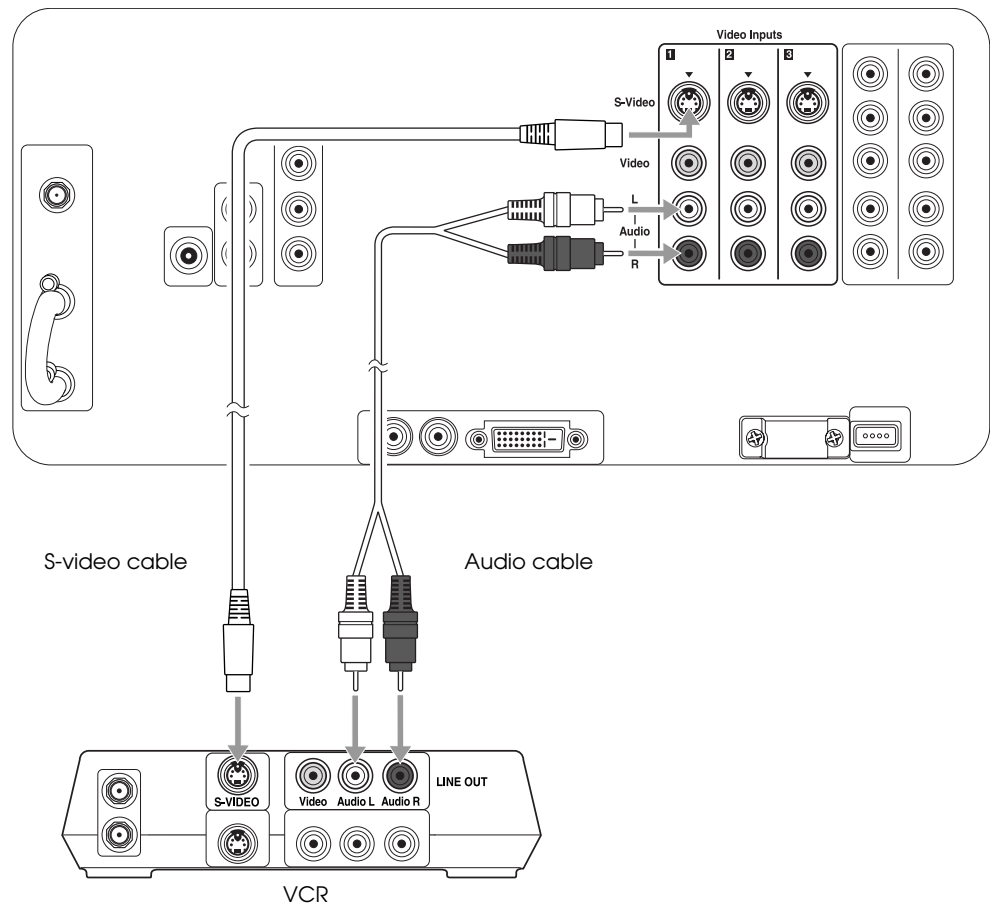

VCR and Cable Service (Without Cable Box) Connection

- 1 Connect the VCR as described in “VCR Connection” on page 24.
- 2 Connect the cable coming into the house to the IN connector on the VCR.
- 3 Connect one end of a coaxial cable to the OUT connector on the VCR.
- 4 Connect the other end of the coaxial cable to the ANT 1 connector on the back of the TV.

If your coaxial cable has a screw-type connector on the end, secure it by turning the end clockwise.

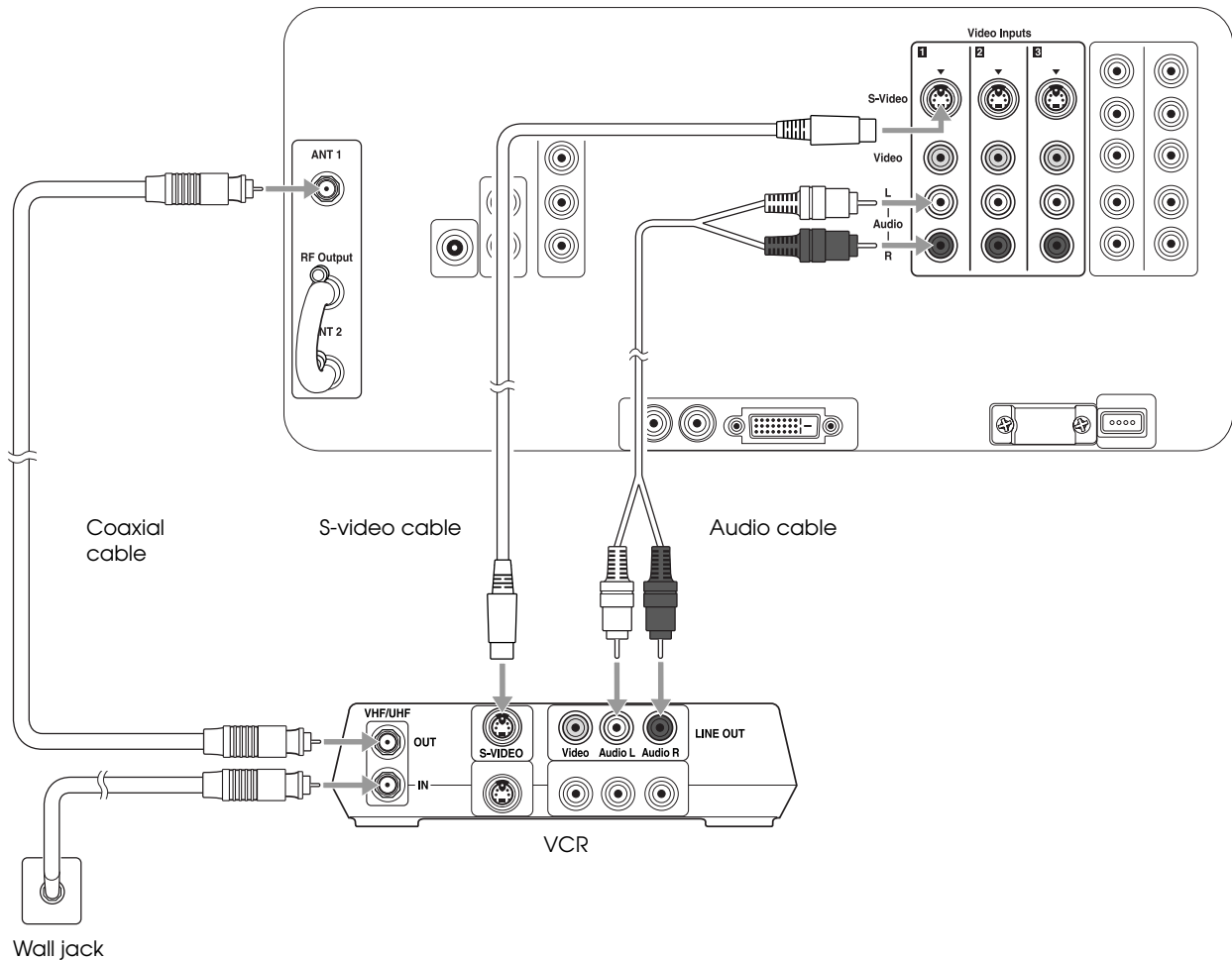

Note

Before connecting a cable box to the TV, be sure to read any instructions that came with the cable box.

Note

Be sure to retain the jumper cable in case you change your TV connections later. You'll need to connect it again in certain connection schemes to provide the channel zapping feature.

VCR and Cable Box Connection

- 1 Turn off and unplug your TV, VCR, and cable box.
- 2 Connect the VCR as described in "VCR Connection" on page 24.
- 3 Connect the cable line coming into the house to the ANT 1 connector on the back of the TV.
- 4 Remove the jumper cable connected to both the RF Output and ANT 2 connectors on the back of the TV. Retain the cable.
- 5 Connect one end of a coaxial cable to the RF Output connector on the back of the TV.
- 6 Connect the other end of the coaxial cable to the IN connector on the cable box. If your coaxial cable has a screw-type connector on the end, secure it by turning the end clockwise.
- 7 Connect another coaxial cable to the OUT connector on the cable box.
- 8 Connect the other end of the coaxial cable to the IN connector on the VCR.
- 9 Connect another coaxial cable to the OUT connector on the VCR.
- 10 Connect the other end of the coaxial cable to the ANT 2 connector on the back of the TV.
- 11 Be sure to turn on use of the TV's ANT 2 port, as described on page 47.

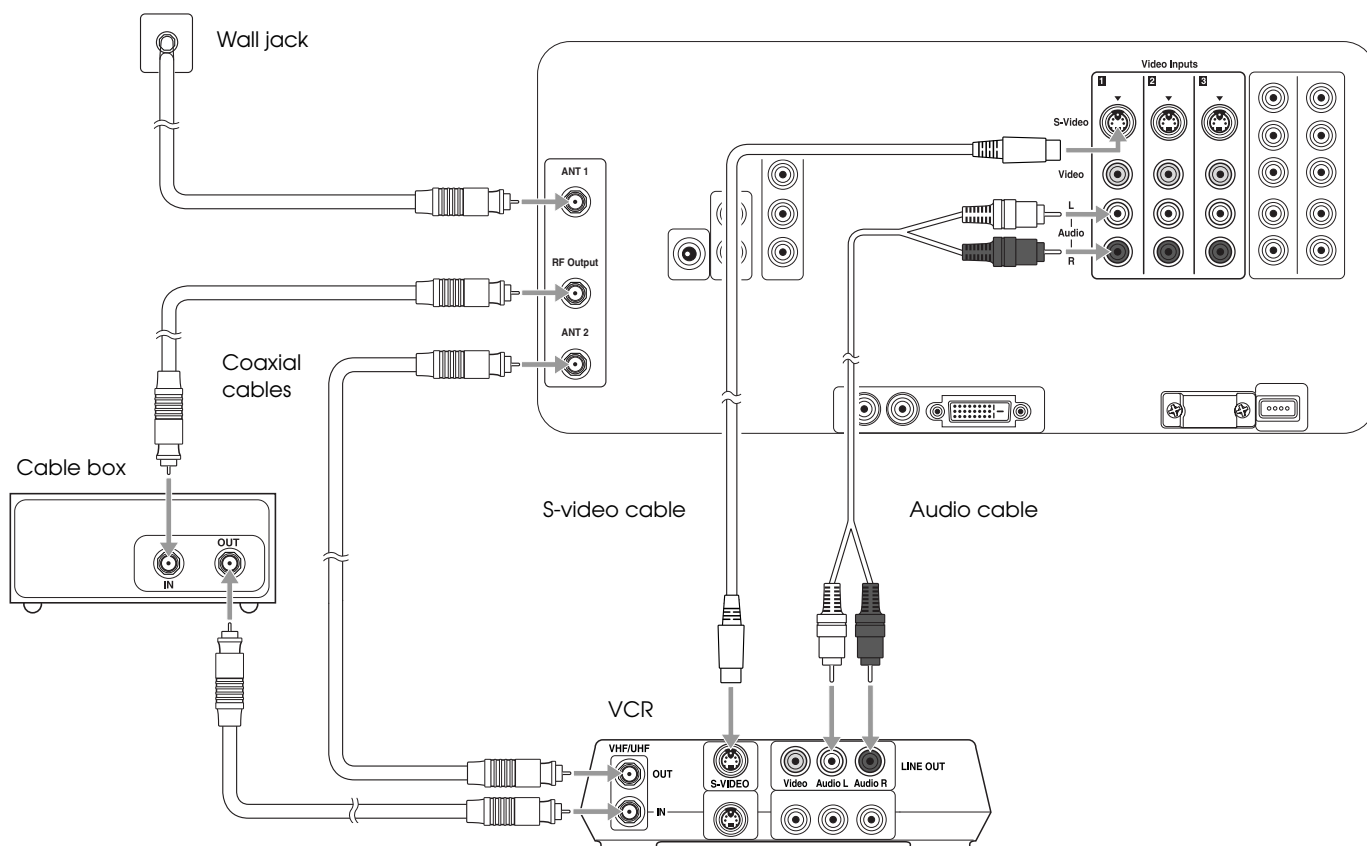

- 12 Plug your TV, VCR, and cable box back into an electrical outlet.

VCR and Satellite Receiver Connection

- 1** Turn off and unplug your TV, VCR, and satellite receiver.
- 2** Connect the VCR as described in “VCR Connection” on page 24.
- 3** Connect the satellite antenna cable to the **Satellite In** connector on your satellite receiver.
- 4** Connect one end of an S-video cable to one of the S-video connectors on your satellite receiver.

(If your satellite receiver uses a DVI connection, connect a DVI cable instead, as shown on page 21. If it uses a component video connection, connect it as shown on page 22.)

- 5** Connect the other end of the S-video cable to one of the S-video connectors on your VCR.
- 6** Connect one end of a standard, red/white audio cable to the **R and L Audio Line Out** connectors on your satellite receiver.
- 7** Connect the other end of the audio cable to the **R and L Audio Line In** connectors on your VCR.

Note

Before connecting a satellite receiver to the TV, be sure to read any instructions that came with the receiver.

Note

If your satellite receiver doesn't have an S-video connector, you can connect a video cable (yellow) to the Video connectors instead of the S-video cable using these instructions.

It's best to connect your satellite receiver to the S-Video connectors on the back of the TV to free up the S-Video connector on the front to connect a camcorder.

- 8 If your satellite service does not include local channels, you can also connect an outside antenna or cable service line to the VHF/UHF IN connector on the VCR. Then connect a coaxial cable to the VHF/UHF OUT connector and to the ANT 1 connector on the back of your TV.

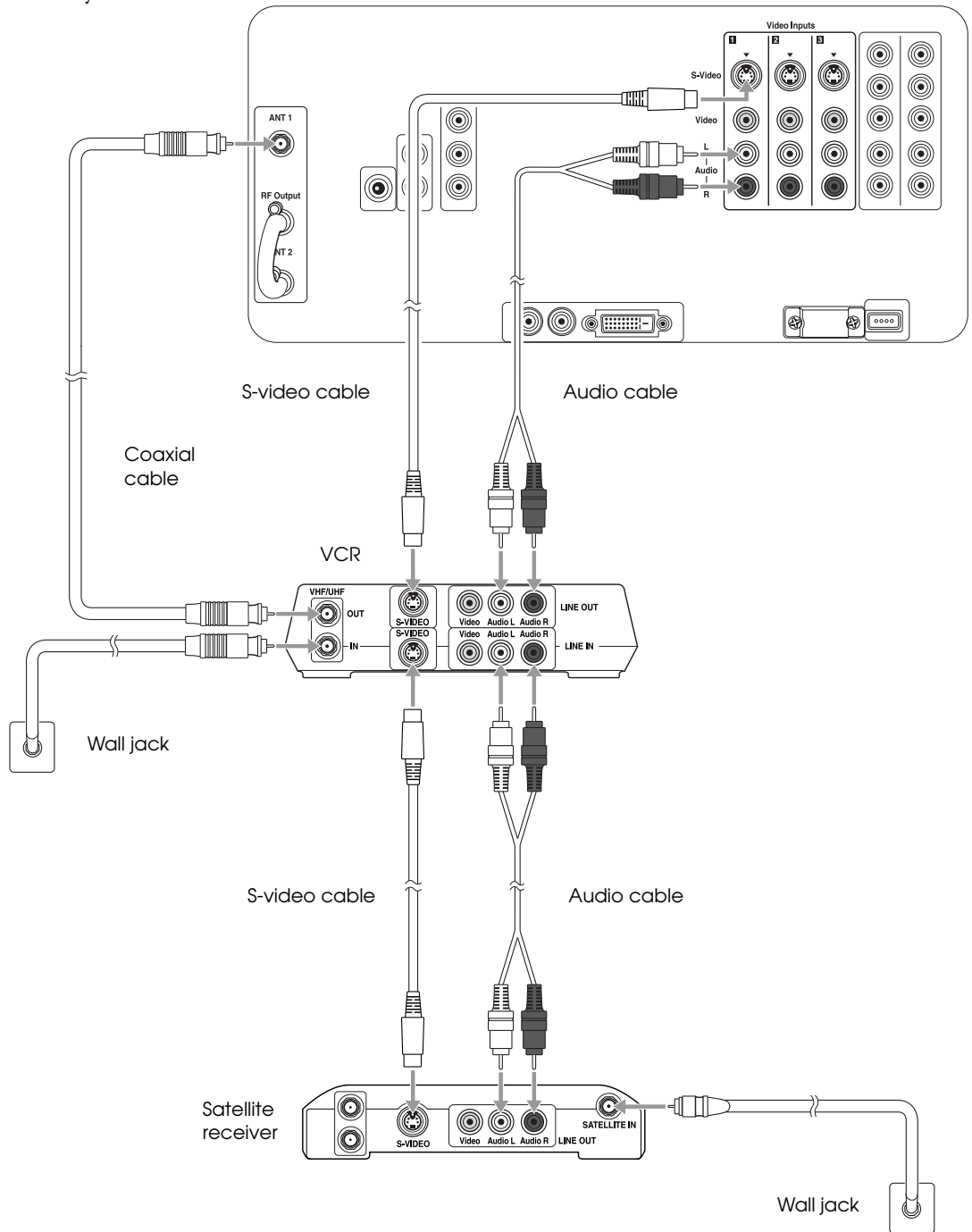

- 9 Plug your TV, VCR, and satellite receiver back into an electrical outlet.

Stereo Amplifier Connection

- 1 Connect one end of a standard, red/white audio cable to the R and L Audio Output Variable connectors on the back of your TV.
- 2 Connect the other end of the audio cable to the R and L Audio Line Input connectors on your stereo amplifier.

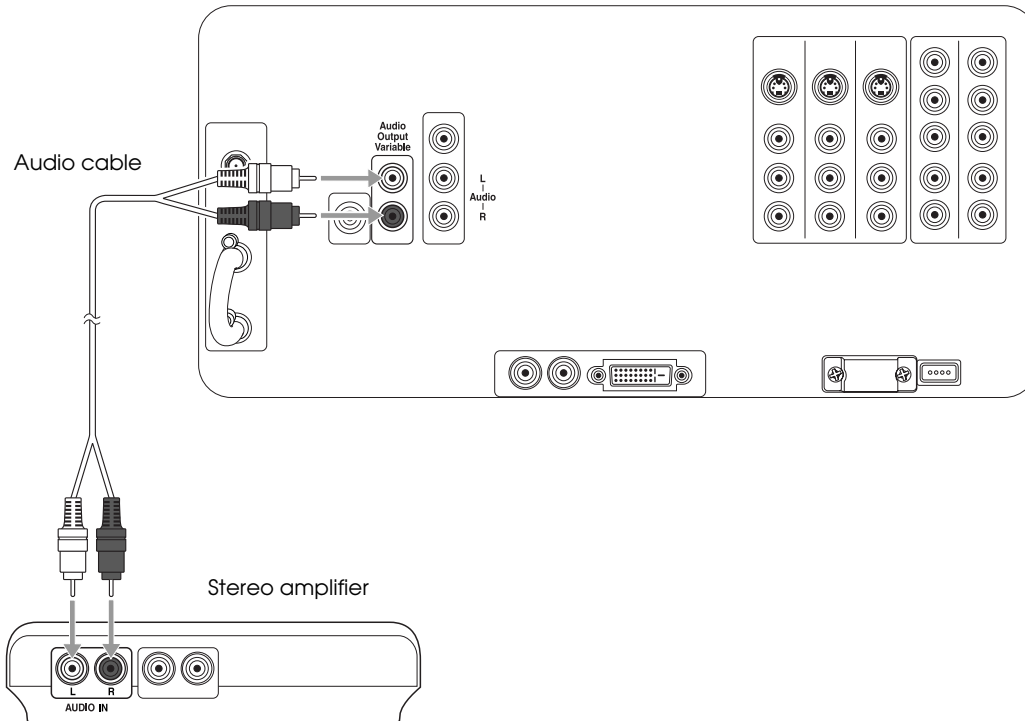

- 3 Turn the TV's speaker volume all the way up to the maximum level. Then use your amplifier remote control to adjust the volume.

Note

You can't connect external speakers to the TV directly; you must connect them to a stereo amplifier.

For best sound quality, you may want to connect the amplifier directly to your audio sources (DVD player, HDTV tuner, etc.).

PC or Game Console Connection

- 1 For a PC, connect one end of a Dsub15 RGB for PC cable to the monitor or PC output connector on the back of your PC.

For a game console, just use the cable that came with the console.

- 2 Connect the other end of the cable to the PC connector on the front of the TV.

- 3 Connect any necessary audio cables to your device and to the Video Inputs R and L Audio connectors on the front of the TV.

Note

To display images on your laptop monitor and the TV screen at the same time, you may need to press the Fn or  button on your laptop. See your computer documentation for details.

If you have any trouble switching to the PC input source, make sure you didn't turn off the Use of PC Input setting. See page 43 for details.

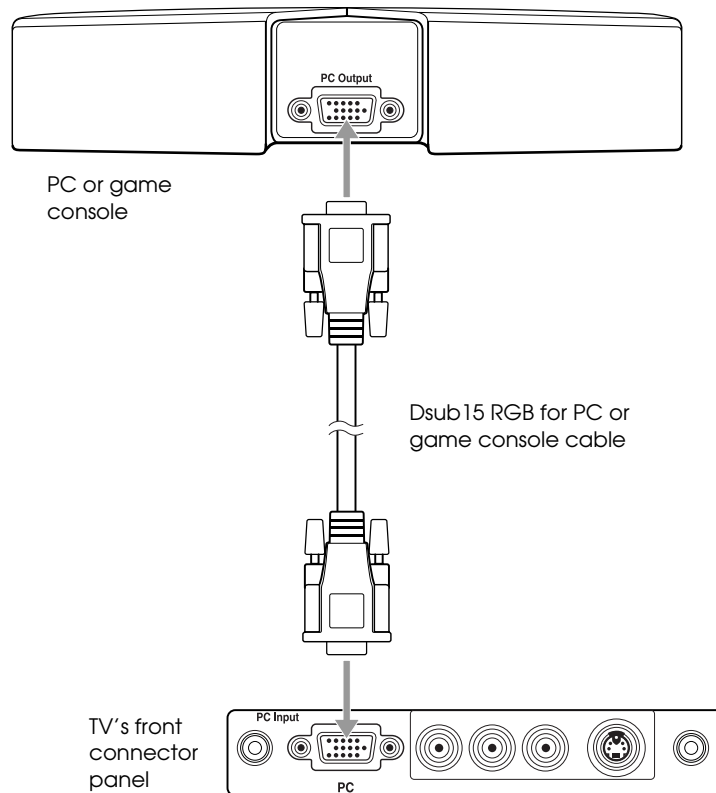

Camcorder, Digital Camera, or Other Portable Video Connection

It's best to connect a portable video device to the S-Video or Video connector on the front of the TV; however, you can use the connectors on the back. These instructions use a camcorder as an example.

- 1 Connect one end of an S-video cable to the S-Video connector on the front of the TV beneath the connector cover.
- 2 Connect the other end of the S-video cable to the S-Video connector on your camcorder.
- 3 Connect one end of a standard, red/white audio cable to the Video Inputs R and L AUDIO connectors on the front of the TV.
- 4 Connect the other end of the audio cable to the R and L A/V Output connectors on your camcorder.

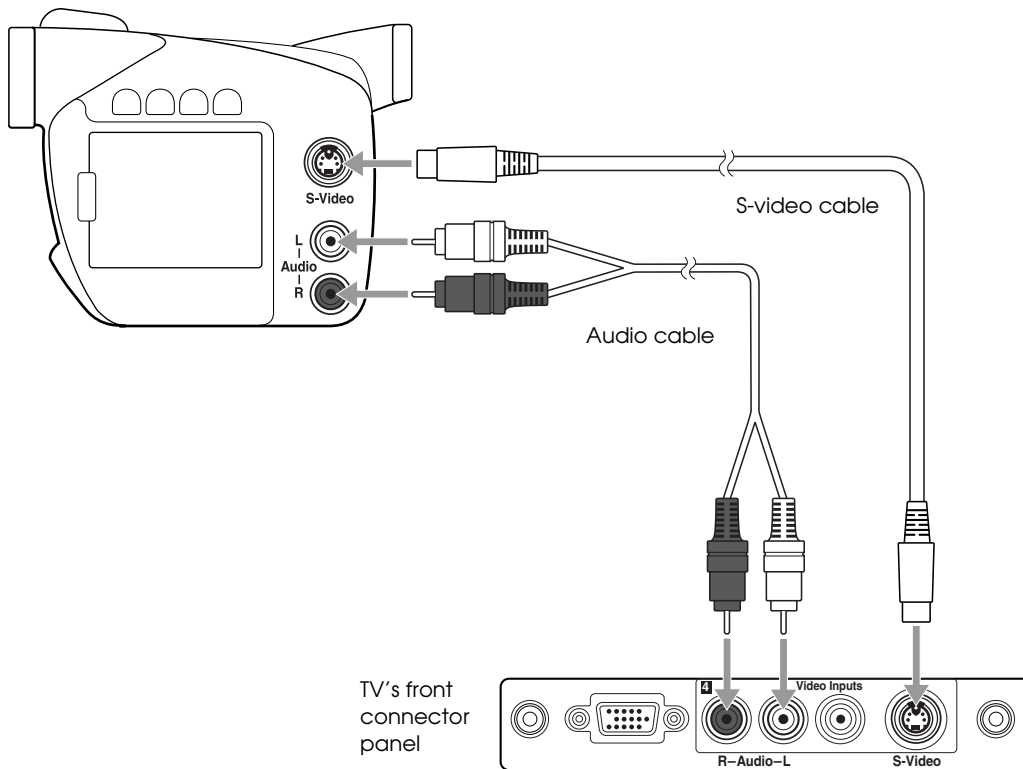

Note

If your device doesn't have an S-video connector, you can connect a video cable (yellow) to the Video connector instead of the S-video cable using these instructions.

If you're connecting a device with mono audio, connect the left (white) cable to the L A/V Output connector on your device and the L Audio connector on the front of the TV.

If you connect your device to a video connector on the TV's front panel, select Video 4 as the input source using the TV/Video button.

Other Optional Device Connections

Note

When you connect headphones, the TV speakers are turned off, but sound is still audible from any audio source you have connected to the TV.

Headphones

Connect headphones to the Headphone connector on the front of the TV.

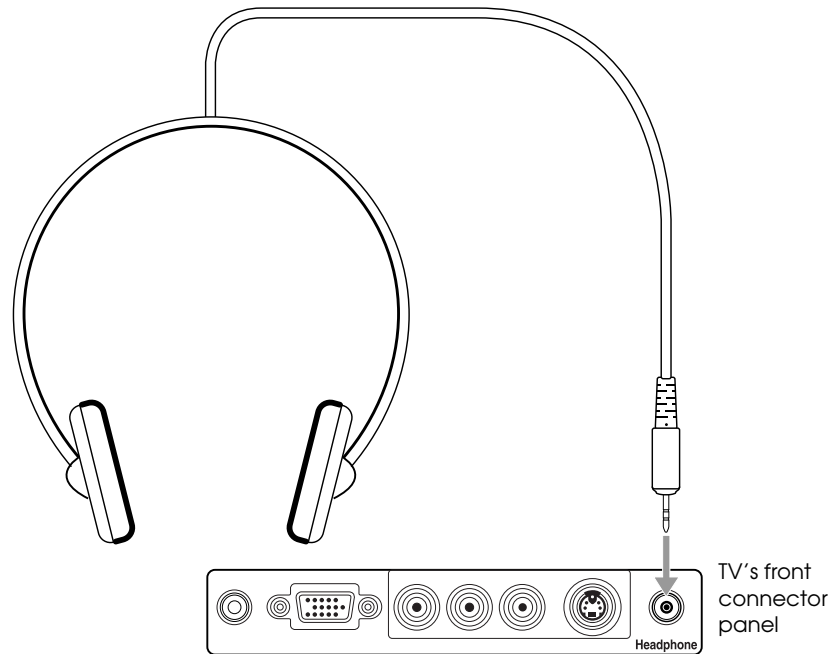

Remote IR Repeater

Connecting a remote IR repeater lets you control other equipment (such as a VCR or DVD player) by using its remote control pointed at the TV's remote control receiver on its front panel.

Connect the remote IR repeater to the Remote-out connector on the back of the TV using the cable that came with the repeater.

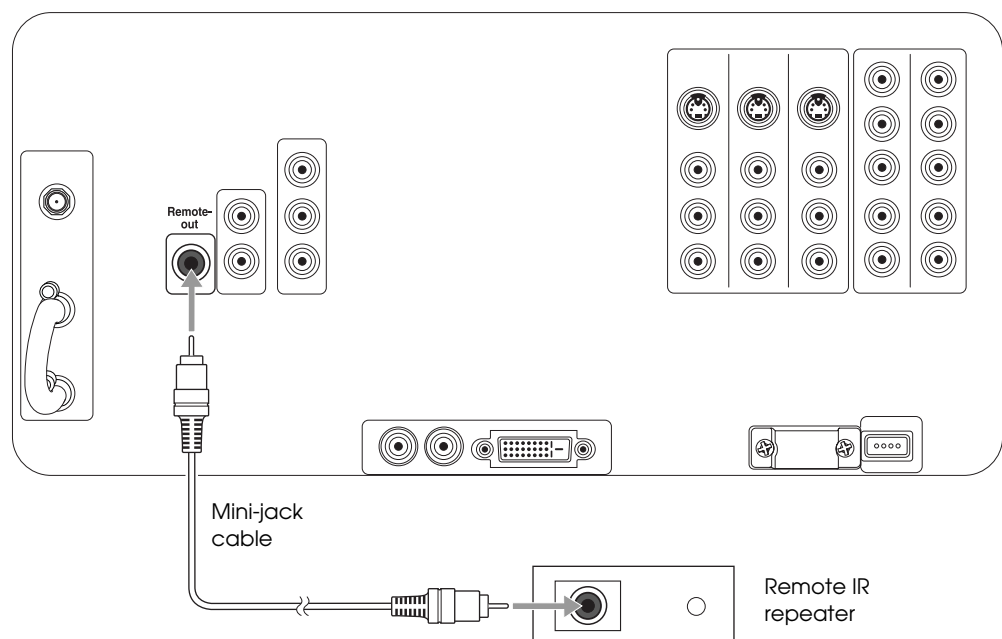

Preparing the Remote Control

Before you can use the remote control, you need to insert the batteries and make sure you aim it correctly. For a description of its functions when using it to operate the TV, see the inside front cover of this book; for instructions on using it with the HDTV tuner, see page 35.

Inserting the Batteries

The remote control uses two AA batteries. You'll need to install the batteries that came with your TV before you can use the remote control.

- 1 Press in on the top of the battery cover on the back of the remote control. Then slide the cover down and off the remote.

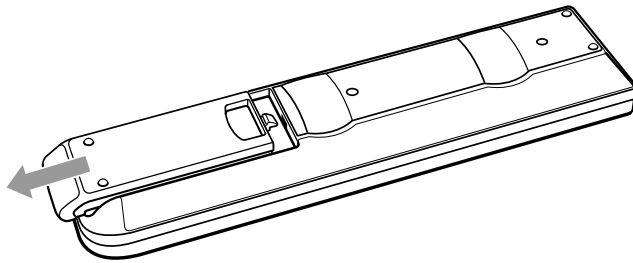

- 2 Insert the batteries as shown below, making sure the + and – ends face the right way. Then push them down flat.

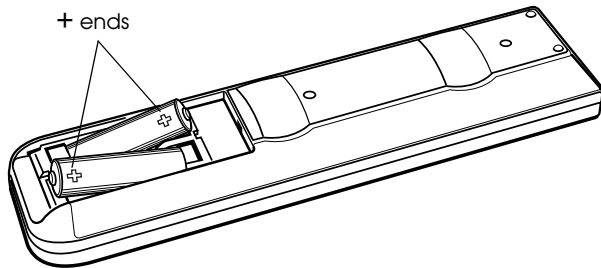

- 3 Place the cover into the grooves and slide the cover all the way up until it clicks into place.

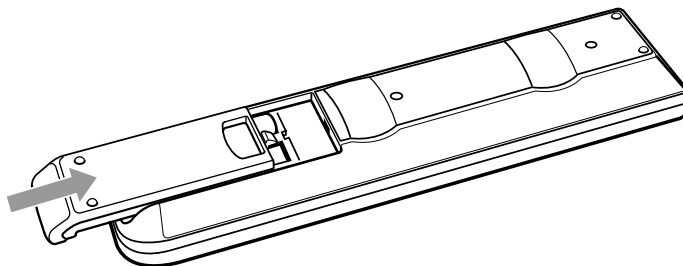

Caution

When you replace the batteries, take the following precautions:

Don't mix old and new batteries.

If the batteries leak, wipe away the battery fluid with a soft cloth. If fluid gets on your hands, wash them immediately.

Remove the batteries if you won't be using the TV for a while.

Dispose of old batteries in accordance with the regulations in your area.

Operating the Remote Control

Aim the remote control at the front of the TV, within about a 25° horizontal angle to the left or right and a 15° vertical angle up or down from the remote receiver.

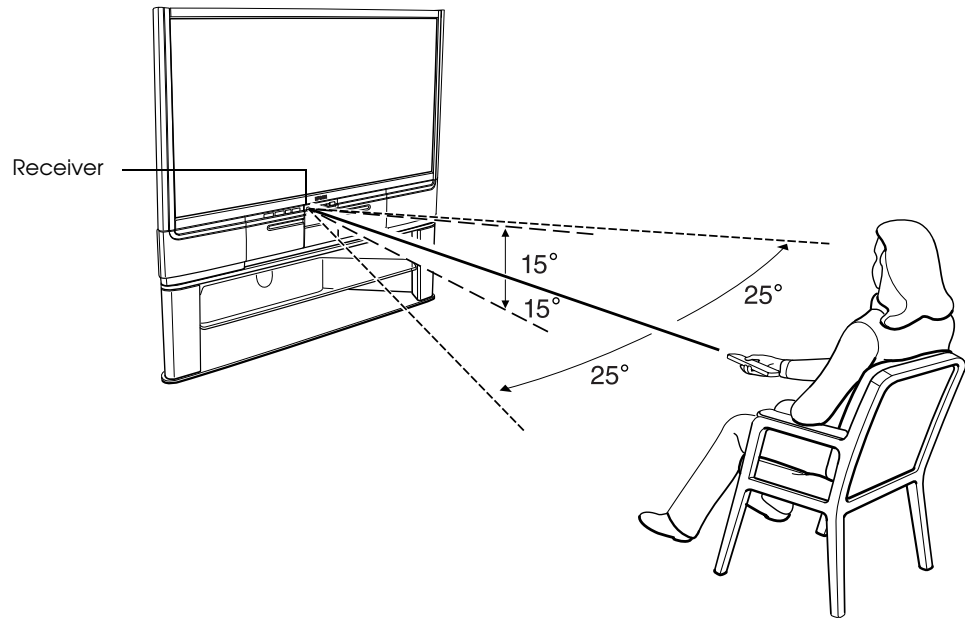

Make sure the room lighting is not too bright and not shining directly on the remote control or the TV receiver window. Keep the transmitter area on the top of the remote and the TV receiver window clean.

To turn off the remote control's beeping sound, hold down the **Menu** button for 2 seconds, until the remote control light stops flashing. Then press the **Volume** down button. (To turn it back on, hold down the **Menu** button for 2 seconds, until the remote control light stops flashing. Then press the **Volume** up button.)

Remote Control Information

The TV may not respond to remote control commands under the following conditions:

- There is an object between the remote control IR emitter and the IR receiver on the TV.
- Ambient light is too bright.
- Certain types of fluorescent lighting are used.
- A strong light source shines into the IR receiver.
- Other equipment that emits infrared energy, such as a radiant room heater, is in the room.

If these conditions cause problems for your TV's remote control, try the following:

- The remote control's batteries may be low on power; replace them.
- Dim the ambient lighting and/or turn off any fluorescent lights.
- Close any window coverings and/or move the TV out of direct sunlight.
- Turn off other equipment that emits infrared energy.

Controlling the HDTV Tuner With the Remote Control

You can use the TV's remote control to operate the HDTV tuner that came with your TV (tuner not included in all areas). That way, you only need to keep one remote control at hand.

- 1 Move the equipment switch at the top of the TV remote control to the STB1 (Set-Top Box 1) position. This position lets you operate the HDTV tuner.
- 2 Use the remote control to operate the tuner, as described below. See the tuner *User's Guide* for details.

Note

You can also program the remote to operate other equipment you have connected to the TV. See page 36 for instructions.

Slide to STB1

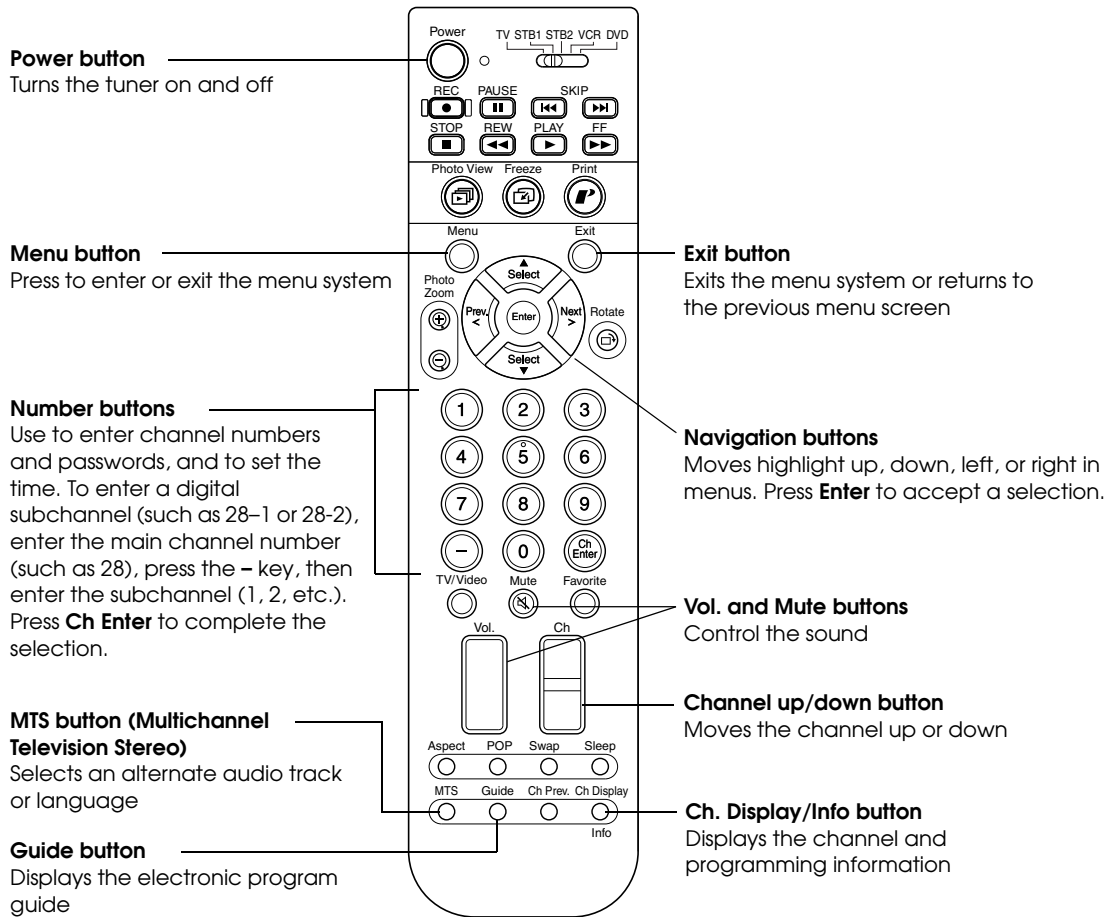
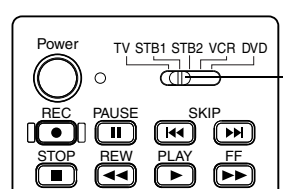

When you want to operate the TV again, slide the equipment switch on the remote control back to the TV position.

Note

If there are multiple codes listed for your equipment manufacturer and the first one you choose doesn't work, try another code.

After you replace the remote control's batteries, you will still be able to use it to operate the TV and tuner. But you will have to re-enter the codes for any other equipment that you want to control.

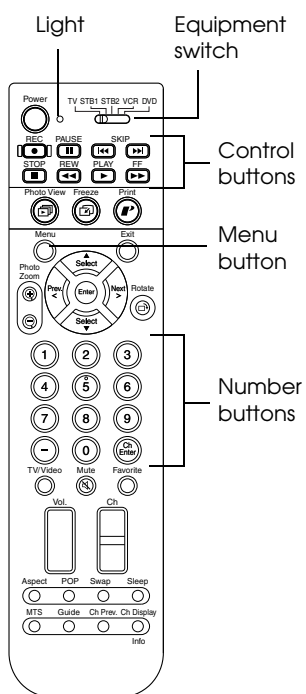

Controlling Other Equipment With the Remote Control

You can program the remote control to operate other home theater equipment, such as a DVD player, VCR, or satellite receiver. That way, you can use just one remote control when watching movies or TV programs.

First you must program your remote control so it knows what kind of equipment you're using. You do this by entering a code that corresponds to the equipment and its manufacturer.

Programming the Remote Control

- 1 Look up the three-digit code for your equipment and manufacturer in the tables beginning on page 37.
- 2 Slide the equipment switch on the top of the remote control to the setting for your equipment type. For example, to enter a DVD player code, slide the switch to the DVD setting. If you reprogram the STB1 setting, you won't be able to use the remote control to operate the HDTV tuner that may have come with your TV, unless you re-enter the tuner's code (101).
- 3 Hold down the **Menu** button on the remote control until its light comes on (about 2 to 3 seconds).
- 4 Enter the three-digit code using the remote control number buttons (for example, 420). The remote control beeps once.

If it beeps 3 times, you've entered an invalid code. Repeat steps 3 and 4 using the correct code.

Using the Programmed Remote Control With Your Other Equipment

Once you've programmed the remote control, follow these steps to use it to control your equipment:

- 1 Slide the equipment switch at the top of the remote control to the type of equipment you want to control, such as DVD.
- 2 Use the 8 buttons on the top of the remote control to play and stop movies, skip and pause tracks, etc.

When you want to operate the TV again, slide the equipment switch on the remote control back to the TV position.

Remote Control Programming Codes

The programming code for the Epson Livingstation HDTV tuner is 101. Codes for other manufacturers' products are listed below.

DVD player programming codes

Manufacturer	Code	Manufacturer	Code
Aiwa	420	Phillips	401, 426, 433
Denon	406, 423	Pioneer	415, 416
Funai	435	Proscan	424, 425
Harmon/Kardon	410	RCA	424, 425
Hitachi	407, 422	Samsung	421
JVC	413, 414	Sanyo	401
Kenwood	431	Sharp	427, 434
Konka	403, 404	Sony	417, 418
LG	411	Sylvania	409
Magnavox	401, 426	Thomson	419
Mitsubishi	412	Toshiba	401, 402
Onkyo	408, 432	Yamaha	406, 428, 426, 433
Panasonic	405, 406, 429, 430	Zenith	411

VCR programming codes

Manufacturer	Code	Manufacturer	Code
Admiral	364	Mitsubishi / MGA	316, 341, 342, 343, 355, 356, 357, 359
Adventure	336	Montgomery Ward	358, 364
Aiko	346	Motorola	328, 364
Aiwa	319, 336, 363	MTC	329, 336
Akai	321, 322, 323, 353, 355	Multitech	307, 315, 329, 333, 336, 357
American High	328	NEC	308, 310, 311, 343, 353, 354
Asha	329	Nikko	319
Audio Dynamic	310, 343, 354	Nobelex	329
Audiovox	319	Olympic	328, 351
Bell & Howell	311, 312	Olympus	328
Beaunmark	329	Optimus	319, 355, 364
Broksonic	334, 337, 338, 354	Optonica	358
Calix	319	Orion	334, 348
Candle	310, 314, 319, 329	Panasonic	325, 326, 327, 328, 351, 352

VCR programming codes (continued)

Manufacturer	Code	Manufacturer	Code
Canon	328, 351	Pentax	316
Carver	349	Pentax Research	310
CCE	333, 346	Philco	312, 328, 334, 349, 351
Citizen	310, 314, 319, 329, 346	Phillips	319, 328, 349, 351, 358
Colortyme	310	Pilot	319
Colt	333	Pioneer	316, 343, 350, 351
Craig	313, 319, 329, 333	Proscan / RCA	304, 305, 306, 314, 315, 316, 323, 328, 329, 349, 351, 365, 366, 367
Curtis Mathes	305, 308, 310, 328, 329, 336, 351, 366	Protec	333
Cybernex	329	Pulsar	324
Daewoo	312, 314, 328, 336, 338, 346	Quarter	311
DBX	308, 310, 343, 354	Quartz	311
Dimensia	364	Quasar	325, 326, 328, 351, 352
Synatech	336	RCA / Proscan	304, 305, 306, 314, 315, 316, 323, 328, 329, 349, 351, 365, 366, 367
Electrohome	319, 355	Radio	311, 313, 318, 319, 328, 329, 336, 351, 355, 358, 364
Electroponic	319	Radix	319
Emerson	308, 312, 314, 319, 320, 329, 334, 335, 336, 337, 338, 339, 341, 346, 347, 355, 356	Randex	319
Fisher	311, 313, 317, 318, 319, 333	Ricoh	301
Fuji	303, 328	Runco	324
Funai	336	Samsung	307, 314, 315, 316, 321, 329, 340
Garrard	336	Sankyo	324, 364
General Electric	305, 315, 328, 329, 349, 351, 365, 366	Sansui	343, 353, 354,
Go Video	330	Sanyo	311, 312, 313, 319, 329
Goldstar / LG	310, 319	Scott	307, 313, 314, 337, 338, 339, 341, 355, 357, 359
Grandiente	336	Sears / LXI	317, 319, 328
Harley Davidson	336	Sharp	355, 358, 364
Harmon Kardon	310	Shintom	301, 316, 333
Harwood	333	Shogun	329

VCR programming codes (continued)

Manufacturer	Code	Manufacturer	Code
Headquarter	311	Signature 2000 (M. Ward)	336, 364
Hitachi	316, 331, 332, 351, 353	Singer	301, 328, 333
Hi-Q	313, 314	Sony	301, 302, 303, 360, 361, 362
Instant Replay	328, 351	STS	316, 328
JC Penney	308, 310, 311, 316, 317, 319, 328, 329, 343, 351, 354	SV2000	328
JCL	328	Sylvania	328, 336, 341, 349, 351
Jensen	316, 353	Symphonic	336
JVC	308, 310, 311, 343, 344, 345, 353, 354	Tandy	311
Kenwood	308, 310, 311, 319, 343, 351, 354	Tashiro	319
KLH	333	Tatung	308, 310, 353, 354
Kodak	319, 328	Teac	308, 310, 336, 353, 354
LG / Goldstar	310, 319	Technics	325, 328, 351
Lloyd	336	Ter (k) nika	309, 319, 328, 336, 351
Logik	333	Toshiba	314, 316, 317, 318, 322, 341
LXI (Sears)	311, 313, 316, 317, 318, 319, 322, 328, 336	Totevision	319, 329
Magnavox	324, 326, 328, 349, 351	TMK	308, 320, 329
Magnin	329	Unitech	329
Marantz	308, 310, 311, 319, 328, 343, 349, 351, 354	Victor Research	310, 314, 343
Marta	319	Victor	343
Matsushita	328	Videoconcepts	310, 314, 343, 355
Mei	328	Videosonic	329
Memorex	311, 313, 324, 328, 329, 336, 341, 351, 364	Wards	313, 314, 316, 319, 324, 328, 329, 333, 336, 351, 355, 358, 364
MGA (Mitsubishi)	316, 341, 342, 343, 355, 356, 357, 359	XR-1000	328, 333, 336
MGN Tech	329	Yamaha	308, 310, 311, 313, 341, 343, 353, 354
Midland	315	Zenith	301, 303, 324
Minolta	316		

Satellite receiver programming codes

Manufacturer	Code	Manufacturer	Code
Alphastar	150	Philips	140
Echostar	147, 148	Primestar	149
GE	144, 145, 146	RCA / Proscan	144, 145, 146
GI (Motorola)	149	Sony	143
Hitachi	137, 138	Toshiba	136
Hughes	137	Uniden	141
JVC	147	Radio Shack	142
Magnavox	140	Zenith	139
Panasonic	150		

Cable box programming codes

Manufacturer	Code	Manufacturer	Code
ABC	118, 119, 120, 121, 129, 133	Regal	125, 126, 127, 128
Color Voice	103, 104	Rembrandt	118
Contec	131	Samsung	134
Garrod	117, 118, 119, 120, 121, 122, 123, 124, 129	Scientific Atlanta	110, 111, 132, 133
Gemini	112, 123	Signal	123
GI (General) (Motorola)	117, 118, 119, 120, 121, 122, 123, 124, 129	Signature	118
Hamlin	125, 126, 127, 128	Sprucer	106
Hitachi	118	Starcom	120, 121, 123
Jerrold	117, 118, 119, 120, 121, 122, 123, 124, 129	Stargate	123
Magnavox	116	Starquest	123
Oak	102, 130, 131	Tocom	129
Panasonic	106, 109, 115	Tusa	123
Philips	103, 104, 112, 116	United Cable	120
Pioneer	114, 134	Videoway	107
Radio Shack	123	View Star	116, 131
RCA / Proscan	113, 115, 106	Zenith	105, 108

 DirecTV[®] receiver programming codes

Manufacturer	Code	Manufacturer	Code
Funai	101	Sony	153
Motorola	154	Voom	155
Samsung	151, 152		

Plugging In and Turning On the TV

After your video and audio equipment are connected and the remote control is ready, you can plug in and turn on the TV. You may want to turn on your connected equipment and insert a tape or disc, if necessary, to test the TV with all of its video and audio sources.

- 1 Plug the power cord into a wall outlet or power strip.
The **Power** light comes on orange.
- 2 If you're using the remote control, make sure the equipment switch at the top is in the TV position.
- 3 Press the **Power** button on the TV panel or the remote control.

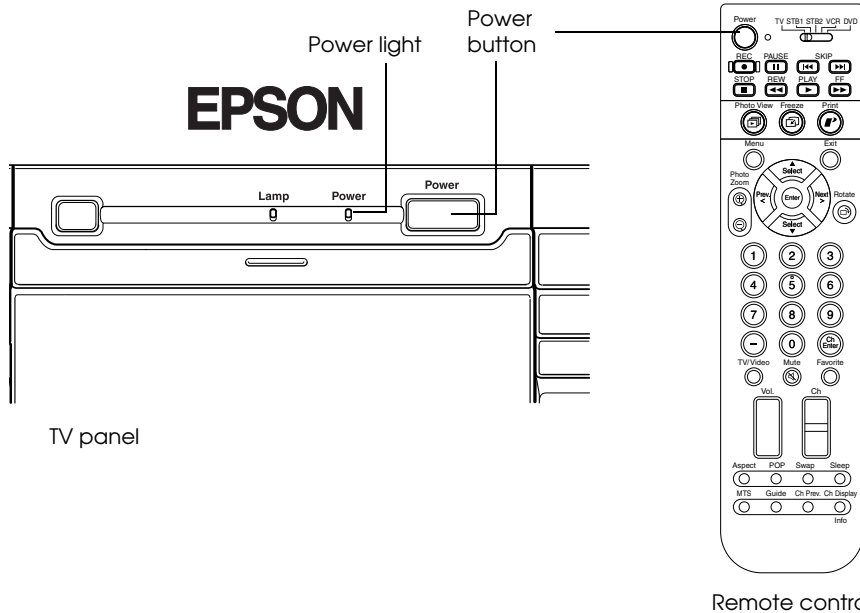

The **Power** light flashes green while the TV warms up.

After a few moments, the **Power** light stops flashing and shines green.

- 4 Press the **TV/Video** button on the remote control or the TV panel to select the source you want to look at (TV, DVD, etc.).

Note

You can press the **TV/Video** button 10 seconds after pressing the **Power** button. You don't have to wait for the **Power** light to stop flashing first.

To turn off the DVI and PC ports when you're not using them (so you don't have to cycle through them with the **TV/Video** button), see the instructions on page 43.

If you see a blank screen with No Signal at the bottom:

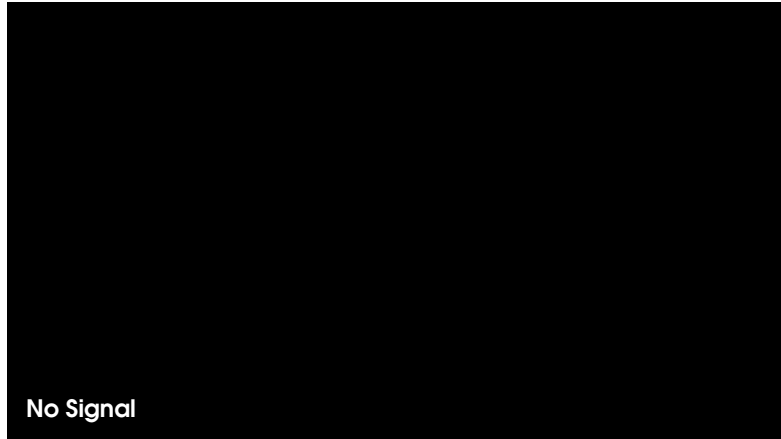

- Turn on the source (VCR, DVD, etc.)
- Insert a disc or tape, if you're viewing one, and press Play
- Press the TV/Video button to select the source
- Check the cable connections
- If it's still not working, see "Basic Operation Problems" on page 112.

Changing the Language of the Menus and Screen Text

You can set the menu system, photo viewer, and other screens to display messages in English, French, or Spanish.

- 1 Press the MENU button on the TV panel or the remote control.
- 2 To highlight the Setting menu tab, press Next >.
- 3 Press Enter. The Auto Aspect setting is highlighted.



- 4 Press Select ▼ to highlight the Language setting.

- 5 Press **Prev <** or **Next >** to select English, Français (French), or Español (Spanish).
- 6 Press **Exit** to select another menu or press **Menu** to exit the menu system.

Skiping Unused Input Sources

As you switch between input sources using the **TV/Video** button, the TV goes to sources to which you've connected equipment. However, the TV goes to the DVI and PC sources even if you aren't using them, unless you turn the ports off.

To turn off the DVI and PC ports when you're not using them (so you don't have to cycle through them with the **TV/Video** button), follow these steps:

- 1 Press the **Menu** button on the TV panel or the remote control.
- 2 To highlight the **Setting** menu tab, press **Next >**.
- 3 Press **Enter**. The **Auto Aspect** setting is highlighted.
- 4 Press **Select ▼** to highlight **Use of DVI Input**.

Note

You can use the buttons on the TV or the remote for all menu operations.



- 5 Press **Prev. <** or **Next >** to turn the setting **OFF**.
- 6 Repeat step 4 and 5 for the **Use of PC Input** setting.
- 7 Press **Menu** to exit the menus.

Labelling Input Sources

It's helpful to label your input sources if you're using more than one device with your TV, such as a DVD player, VCR, etc. Then you can easily recognize the devices as you switch between them. The label appears on the TV screen when you display or switch input sources.

- 1 Press the **MENU** button on the TV panel or the remote control.
- 2 To highlight the Setting menu tab, press **Next >**.
- 3 Press **Enter**. The Auto Aspect setting is highlighted.

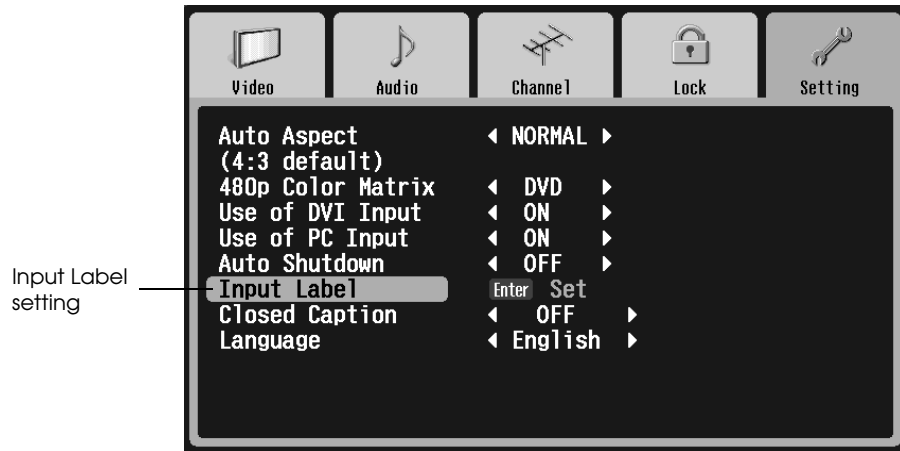

- 4 Press **Select ▼** to move to the Input Label setting.
- 5 Press **Enter**. You see the Input Label screen:

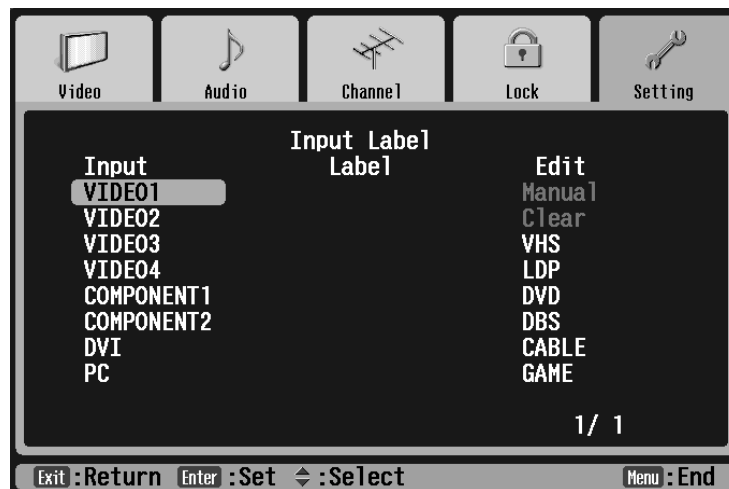

- 6 To label an input source, press **Select ▼** or **Select ▲** to highlight the source in the Input column, such as VIDEO1.
- 7 Press **Enter**. The highlight moves to the top of the Edit column.

Selecting a Predefined Label

- 1 Press **Select ▼** or **Select ▲** to highlight the label you want.

If 1/2 appears in the bottom right corner of the screen, you can press **Next >** to view more predefined labels on a second screen. (Press **Prev <** to return to screen 1.)

- 2 Press **Enter**.

Creating a Custom Label

- 1 Press **Select ▼** or **Select ▲** to highlight **Manual** in the **Edit** column.
- 2 Press **Enter**. The highlight moves to the first character of the label in the **Label** column.

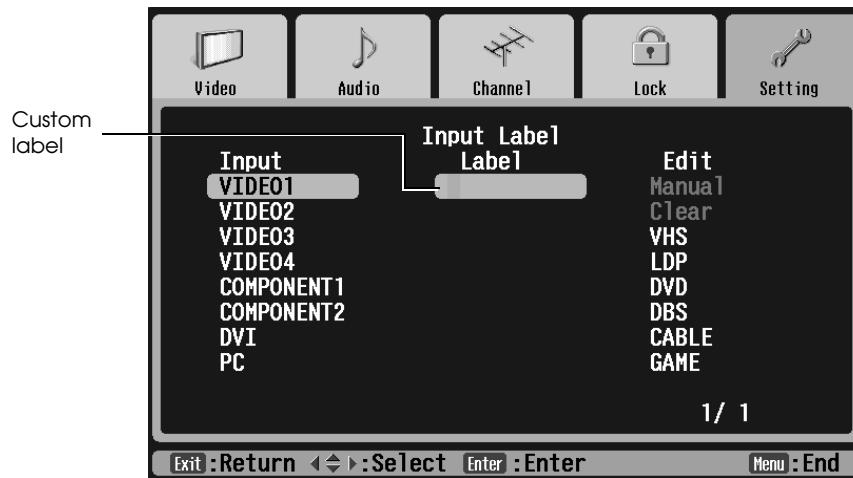

- 3 You can create a label up to 10 characters long, made up of letters, numbers, and/or symbols. To cycle through the letters of the alphabet, press **Select ▼**. To cycle through the symbols and then the numbers, press **Select ▲**. You can hold down the button or press it repeatedly.
- 4 Once you've selected the first character, press **Next >** to move to the next character.
- 5 Repeat steps 3 and 4 until you're finished creating a label. Then press **Enter**.

Deleting a Label

- 1 Press **Select ▼** or **Select ▲** to highlight the source in the **Input** column and press **Enter**.
- 2 Press **Select ▼** to highlight **Clear** in the **Edit** column and press **Enter**. The label disappears from the **Label** column. The input source name will appear when you display or switch your input sources.

Caution

Turn off the TV when not in use. Continuous 24-hour-a-day use may reduce its overall life.

Turning Off the TV

- 1 Press the **Power** button on the TV panel or the remote control.

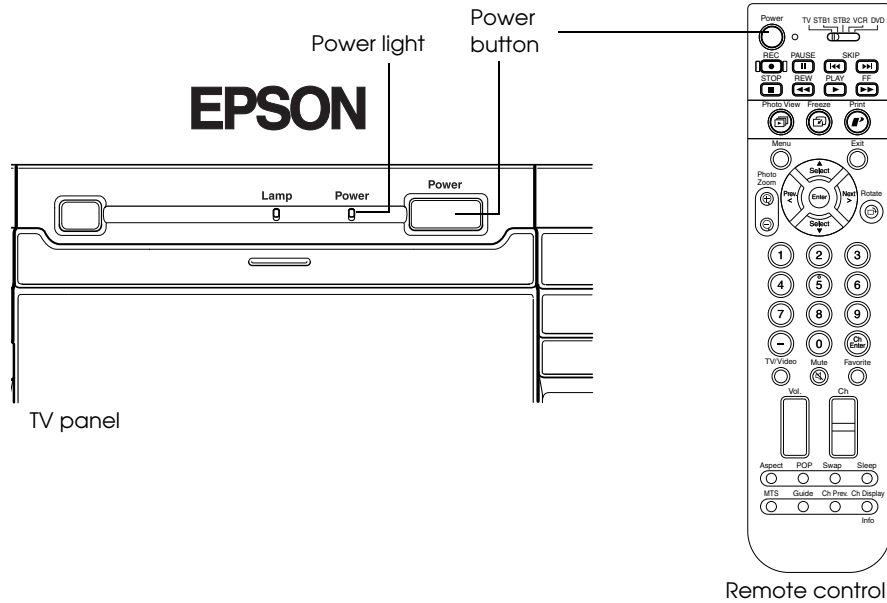

Note

You can also set the TV to turn off automatically after a set period of time (see page 76).

- 2 The **Power** light flashes orange as the TV cools down.

When it's cool, the **Power** light stops flashing and shines orange. Leave the TV like this or unplug it.

Setting Up and Controlling Channels

If you plan to use your TV's built-in tuner to view television programs, you'll need to set up your available channels. You may also want to use the TV's channel control features or block unwanted viewing of channels or input sources by children, as described in these sections:

- "Setting Up Your TV Channels" below
- "Labelling TV Channels" on page 51
- "Selecting Channels" on page 50
- "Setting Up Favorite Channels" on page 50
- "Setting Up Parental Controls" on page 53

Note

If you watch TV programs using an HDTV tuner, or a cable, satellite, or digital TV service with a separate receiver box, you don't need to set up your channels. The tuner or receiver box does that for you.

Setting Up Your TV Channels

If you're receiving your TV programs using a broadcast antenna or a cable system without a cable box, you need to set up the channels that the TV can receive.

You can use Auto Program to automatically search for the available channels and set them up. Then, for channels that are not automatically detected, you can use Manual Program to add them. You can also choose to have the TV "skip" certain channels that you don't want to view.

Automatically Setting Up Your Channels

Before setting up your channels, make sure you've connected your broadcast antenna or cable service line to the ANT 1 or ANT 2 connector on the back of the TV. Then press the TV/Video button on the TV panel or remote control to select your TV signal.

- 1 Press the MENU button on the TV panel or the remote control.
- 2 To move to the Channel tab, press Next >.
- 3 When the Channel tab is highlighted, press Enter. The Antenna 1 setting is highlighted.

Note

You can use the buttons on the TV or the remote for all menu operations.



- 4 First make sure the correct television source type is selected for Antenna 1 and/or Antenna 2. Select TV for broadcast television via an antenna outside your house. Select CATV for cable television via a cable service line brought into your house.

If you need to change the option, press Select ▼ or Select ▲ to highlight the Antenna 1 or Antenna 2 setting, then press Prev < or Next > to change the option.

- 5 If you connected a source to the ANT 2 connector, press Select ▼ to highlight the Use of Ant. 2 setting, then press Prev < or Next > to select On.
- 6 Press Select ▼ to highlight Auto Program, then press Enter.



Note

If you have another TV signal source connected to the other antenna connector (ANT 1 or 2), press the TV/Video button to switch to that source. Then repeat steps 1 through 5 to set up the channels on that source too.

The menu disappears and Auto Program Setting appears in the middle of the screen as the TV begins searching for available channels. It reports the current channel in the upper right corner. This process takes a few minutes, depending on the number of channels available.

When it's finished, you return to the Channel menu.

If the automatic program doesn't detect all of your available channels or if you want to set up the TV to skip certain available channels, follow the steps in the next section.

Manually Adding or Skipping Channels

For channels that are not automatically detected when you use Auto Program, you can use Manual Program to add them. You can also choose to have the TV skip certain channels so you don't have to cycle through them when you change channels.

- 1 Press **Select ▼** to highlight Manual Program, then press **Enter**. The screen changes to the following:



- 2 To select a channel, press **Select ▼** or **Select ▲** until its number is highlighted in the Channel column.

If the channel number you want is not shown on the screen, press **Prev <** or **Next >** to go to the next or previous screen.
- 3 Press **Enter**. The highlight moves to the Add/Skip column.
- 4 Press **Prev <** or **Next >** to select Add or Skip, then press **Enter**.
- 5 To add or skip another channel, repeat steps 2 through 4.
- 6 Press **Exit** to return to the main Channel menu or press **MENU** to exit the menu system.

Note

If you're using an HDTV tuner or a cable, satellite, or digital TV receiver with a separate receiver box, you can select TV channels using the controls that came with the tuner or receiver.

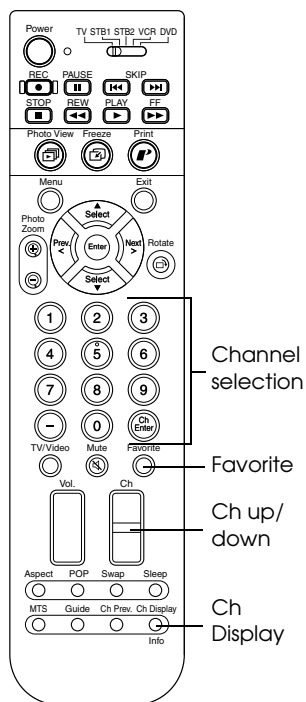

Selecting Channels

To select the channel you want to watch, do one of the following:

- Enter the channel number using the number keys and press **Ch Enter**.
- Press the **Ch +** or **-** button to go up or down one channel at a time.
- Press the **Ch Prev.** button to go back and forth between the previous and current channel.

The channel number and audio mode briefly display in the upper right corner.

If you want to see a channel number after it has disappeared, press the **Ch Display** button. The channel number and audio mode briefly appear, then the channel number remains on the screen. Press **Ch Display** again to turn off the display.

Setting Up Favorite Channels

You can create a group of up to 12 favorite channels that you frequently want to watch. Then you can quickly go to those channels by pressing the **FAVORITE** button on the remote control.

To set up favorite channels, you must be connected to a broadcast antenna or cable TV system without a decoder box so you can control your channels with the TV tuner.

- 1** To set up your favorite channels, first select the channel on your TV.
- 2** Hold down the **FAVORITE** button on the remote control for about 3 seconds.
Registered appears in the upper left corner of the TV screen.
- 3** Select the next channel you want to add as a favorite and repeat step 2. You can add up to 12 favorite channels.

Whenever you want to tune to a favorite channel, press the **FAVORITE** button. Press it again to go to the next favorite channel, and so on.

If you need to delete a channel from the favorites group, select the channel, then hold down the **EXIT** button on the remote control for about 3 seconds. **REMOVED** appears in the upper left corner of the TV screen.

Labelling TV Channels

You may want to label your channels so you can easily identify them by name instead of just by number. The channel label appears with the number in the upper right corner of the screen when you display or switch channels.

- 1 Press the **MENU** button on the TV panel or the remote control.
- 2 To move to the Channel tab, press **Next >**.
- 3 When the Channel tab is highlighted, press **Enter**. The Antenna 1 setting is highlighted.



- 4 Press **Select ▼** to highlight Channel Label, then press **Enter**. You see this screen:



- 5 The first channel is highlighted. If you want to label that channel, press **Enter**.

To select a different channel, press **Select ▼** or **Select ▲**. If you don't see the channel you want, press **Prev <** or **Next >** to display the next or previous screen. Once you've highlighted a channel, press **Enter**. The highlight moves to the Edit column.

Selecting a Predefined Label

- 1 Press **Select ▼** or **Select ▲** to highlight the label (such as CBS) in the Edit column.
If you don't see a particular label, press **Prev <** or **Next >** to display the next screen.
- 2 Press **Enter**. The new label is listed in the Label column and the Channel number is highlighted again.

Creating a Custom Label

- 1 Press **Select ▼** or **Select ▲** to highlight the Manual option in the Edit column and press **Enter**. The highlight moves to the first character of the label in the Label column.

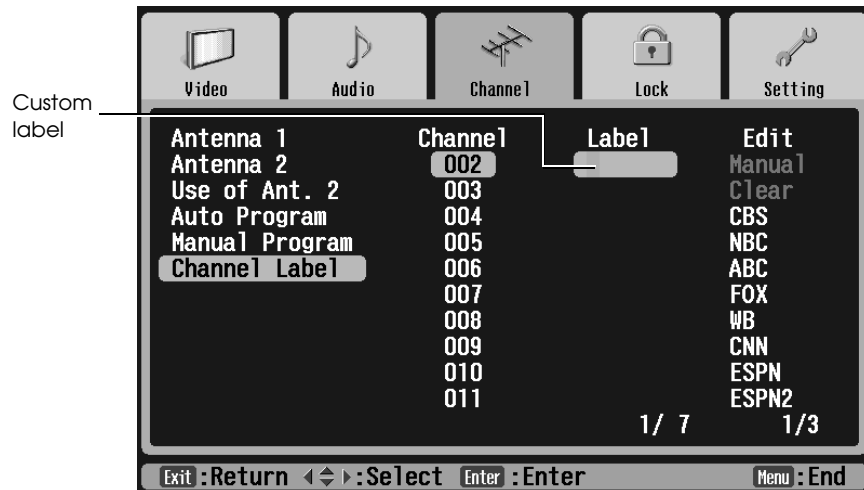

- 2 You can create a label up to 6 characters long, made up of letters, numbers, and/or symbols. To cycle through the letters of the alphabet, press **Select ▼**. To cycle through the symbols and then the numbers, press **Select ▲**. You can hold down the button or press it repeatedly.
- 3 Once you've selected the first character, press **Next >** to move to the next character.
- 4 Repeat steps 2 and 3 until you're finished creating a label. Then press **Enter**.

Deleting a Label

- 1 Press **Select ▼** or **Select ▲** to highlight the channel in the Channel column and press **Enter**.
- 2 Press **Select ▼** to highlight **Clear** in the Edit column and press **Enter**. The label disappears from the Label column. The channel number will appear when you display or switch channels.

Setting Up Parental Controls

You can control access to rated television programs and block access to certain channels and input sources to prevent viewing of unsuitable materials. The person controlling access creates a password that allows him or her to set up, lock, and unlock the parental controls.

Before setting up parental controls, you need to change the default password to a new one. Write down the new password and keep it in a secure place.

Creating a Password

- 1 Press the **Menu** button on the TV panel or the remote control.
- 2 To move to the Lock tab, press **Next >**.
- 3 When the Lock tab is highlighted, press **Enter**. The highlight moves to the first character in the password field:



- 4 First you need to enter the default password to access the Lock menu.

On the remote control, press the **0** button four times (the default password is 0000). Asterisks (*) appear on the screen as you press the buttons.

Note

You can use the buttons on the TV or the remote for all menu operations.

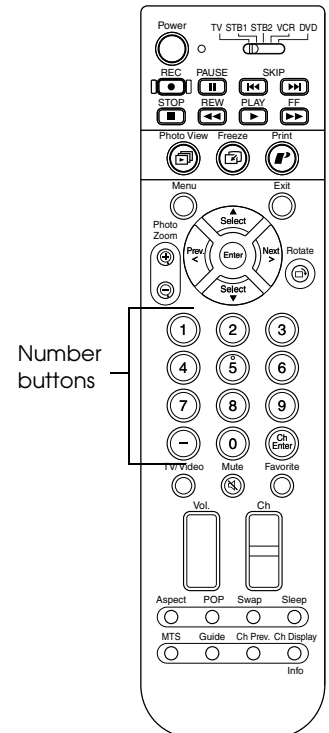

Then you see the Lock menu.



- 5 Press Select ▼ to highlight Password Change, then press Enter. You see this screen:



- 6 Use the number buttons on the remote control to enter a four-digit password.
- 7 Enter the same password again to confirm it. You return to the Lock menu.
- 8 To block programs using V-Chip, see page 55.

To block certain TV channels and/or input sources, such as a game console, see page 59.

To exit the menu system, press Menu.

Blocking Programs Using V-Chip

Your TV is equipped with V-Chip technology that allows you to block the display of TV programs or movies based upon their content rating. You can also block display of programs or movies that don't carry V-Chip ratings (unrated programs). Whenever you need to change the ratings or remove blocking, you need to enter a password.

- 1 Press the **Menu** button on the TV panel or the remote control.
- 2 To move to the **Lock** tab, press **Next >**.
- 3 When the **Lock** tab is highlighted, press **Enter**. The highlight moves to the first character in the password field:



- 4 Using the number buttons on the remote control, enter your password. You see the **Lock** menu.
- 5 Press **Select ▼** to highlight **V-Chip**.



- 6 Press **Prev <** or **Next >** to select **ON**. The **Rating**, **Unrated**, and **Country** settings become available.

Note

When you turn on V-Chip blocking, you can't use channel zapping (described on page 73). To use channel zapping, turn off V-Chip blocking.

- 7 Press Select ▼ to highlight Country, then press Prev < or Next > to select U.S.A. or Canada.
- 8 If you want to block access to programs that don't carry V-Chip ratings, press Select ▲ to highlight Unrated. Then press Prev < or Next > to select Block.
- 9 To set up V-Chip blocking, press Select ▲ to highlight Rating and press Enter.

If you selected U.S.A as the Country setting, you see the U.S.A. Rating screen:



Go to step 10.

If you selected Canada as the Country setting, you see the Canada Rating screen:



Press Select ▼ or Select ▲ to select French Rating, English Rating, or U.S.A Rating, indicating the rating system you want to use (for details, see page 58).

If you selected U.S.A. Rating, go to step 10.

If you selected French Rating or English Rating, press Enter to block programs with the selected rating and any more mature ratings (– means unblocked and X means blocked). Then go to step 13.

- 10 Press Select ▼ or Select ▲ to select TV Rating or Movie Rating, indicating the type of U.S.A. rating you want to set up blocking for. Then press Enter.

11 If you selected TV Rating, you see these options:



All of the ratings are unblocked by default. Press **Select ▼** or **Select ▲** to select an Age Based rating. If desired, press **Prev <** or **Next >** to select a Content Based rating.

Press **Enter** to block programs with the selected rating and any more mature ratings (– means unblocked and X means blocked).

For details on the ratings, see page 58.

12 If you selected Movie Rating, you see these options:



All of the ratings are unblocked by default. Press **Select ▼** or **Select ▲** to select an Age Based rating. Then press **Enter** to block programs with the selected rating and any more mature ratings (– means unblocked and X means blocked).

For details on the ratings, see page 58.

13 Press **Exit** to return to the Lock menu or **Menu** to exit the menu system.

V-Chip Ratings

U.S.A. TV ratings

Rating	Description
Age-based ratings	
TV-Y	All Children Designed to be appropriate for all children, including ages 2 to 6.
TV-Y7	Directed to Older Children Designed for children aged 7 and above.
TV-G	General Audience Designed to be suitable for all ages.
TV-PG	Parental Guidance Suggested Contains material that parents may find unsuitable for younger children.
TV-14	Parents Strongly Cautioned Contains material that many parents would find unsuitable for children under 14.
TV-MA	Mature Audiences Only Designed to be viewed by adults and may be unsuitable for children under 17.
Content-based ratings - may be combined with age-based ratings	
FV	Fantasy Violence
D	Dialogue
L	Language
S	Sexuality
V	Violence

U.S.A. Movie ratings

Rating	Description
G	General Audience
PG	Parental Guidance Suggested
PG-13	Parents Strongly Cautioned
R	Restricted - No One Under 17 Admitted Without a Parent or Adult Guardian
NC-17	No One Under 17 Admitted
X	No One Under 17 Admitted (older version of the NC-17 rating)

French ratings (for Canada)

Rating	Description
G	General Considered appropriate for all age groups.
8 ans+	General for 8 years and older Not appropriate for children under 8 without supervision.
13 ans+	Over 13 years May not be appropriate for children under 13.
16 ans+	Over 16 years May not be appropriate for children under 16.
18 ans+	Adults Intended for viewers 18 years and older.

English ratings (for Canada)

Rating	Description
C	Children Intended for children under 8 years old.
C8+	Children Over 8 Years Old Considered acceptable for children 8 years and older to view by themselves.
G	General Considered acceptable for all age groups.
PG	Parental Guidance Intended for a general audience, but some content may not be appropriate for viewing by unsupervised children in the 8 to 13 age range.
14+	Over 14 Years Contains themes or elements that may not be suitable for viewers under the age of 14.
18+	Adults Intended for viewers 18 years and older.

Blocking Channels and Input Sources

In addition to blocking rated TV programs and movies, you can block access to particular TV channels or input sources, such as those used for game consoles.

- 1 Press the **Menu** button on the TV panel or the remote control.
- 2 To move to the **Lock** tab, press **Next >**.
- 3 When the **Lock** tab is highlighted, press **Enter**.

Note

You can use the buttons on the TV or the remote for all menu operations.

The highlight moves to the first character in the password field:



- Using the number buttons on the remote control, enter your password. You see the Lock menu:

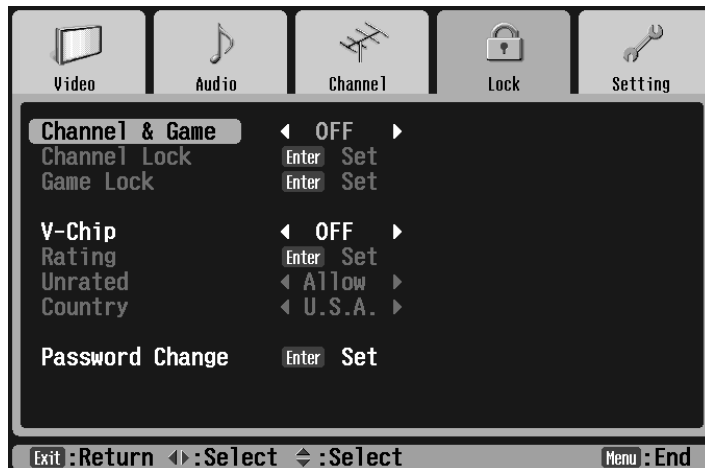

- Channel & Game Lock is highlighted. Press Prev < or Next > to select ON.
- To lock a channel, press Select ▼ to highlight Channel Lock, then press Enter. You see the channel lock options:



- 7 Press **Select ▼** or **Select ▲** to highlight the channel number, then press **Enter**. The highlight moves to the Lock column.
- 8 Press **Prev <** or **Next >** to select Lock or unlock (-). Then press **Enter**.
- 9 Repeat steps 7 and 8 to lock any other channels, then press **Exit** to return to the Lock menu.
- 10 To lock an input source, press **Select ▼** to highlight **Game Lock**, then press **Enter**. You see the input lock options:



- 11 Press **Select ▼** or **Select ▲** to highlight the input source, then press **Enter**. The highlight moves to the Lock column.
- 12 Press **Prev <** or **Next >** to select Lock or unlock (-). Then press **Enter**.
- 13 Repeat steps 11 and 12 to lock any other sources, then press **Exit** to return to the Lock menu.

Accessing Blocked Programs, Movies, Channels, and Input Sources

If you try to access a blocked program, movie, channel, or input source, the TV displays one of the screens shown below:

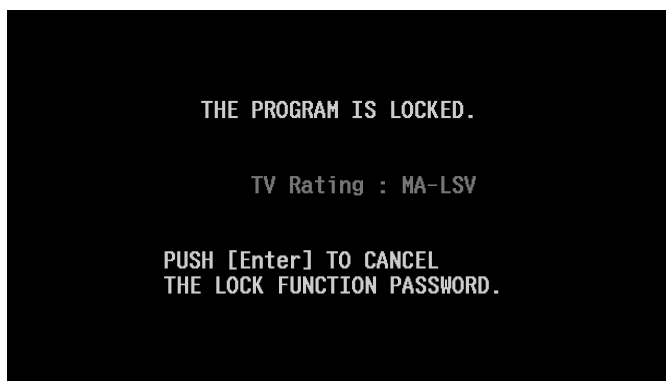

Blocked program or movie (V-Chip) screen

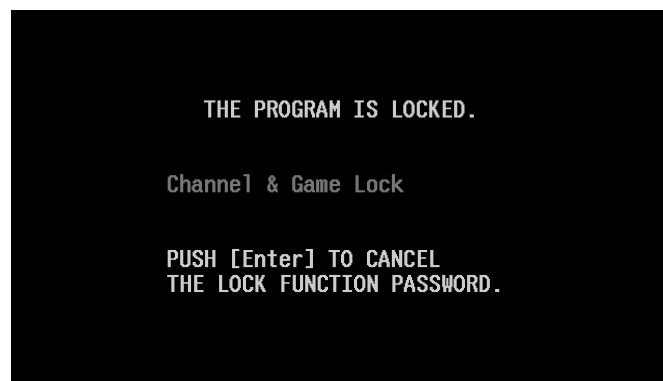

Blocked channel or input source screen

If you see one of these screens and you want to access the program, movie, channel, or input source, follow these steps:

- 1** Press **Enter**. You see a screen asking you to enter your password.
- 2** Enter your 4-digit password using the remote control number buttons.

The program, movie, channel, or input source is unblocked and the blocking feature is turned off.

To set up blocking again, see page 55 (for V-Chip blocking) or page 59 (for channel and input source blocking).

Adjusting the Picture and Sound

You can make adjustments to your TV's picture and sound quality, as described in these sections:

- “Adjusting the Picture Quality” on page 63
- “Selecting the Aspect Ratio” on page 66
- “Adjusting the Sound” on page 68

Adjusting the Picture Quality

Your TV offers three color modes (preset picture settings) that let you quickly adjust the picture for various lighting environments and image types. After selecting a suitable color mode, you can fine-tune the picture by adjusting its brightness, contrast, sharpness, saturation, tint, black level, color temperature, and screen position. You can also create two custom color modes that let you quickly adjust the picture for special viewing needs.

Color modes and picture quality adjustments are saved independently for each image source. Before changing settings, select the source you want to adjust (for example, HDTV tuner or DVD player) and display a picture. After you finish adjusting the settings for this source, switch to each additional source you'll be viewing and make any desired adjustments.

- 1 Select the source you want to adjust and display a picture.
- 2 Press the **Menu** button on the TV panel or the remote control.
- 3 Press the **Enter** button. The Color Mode setting is highlighted.

Note

Depending on your input source, not all of the picture quality adjustments may be available.

Note

You can use the buttons on the TV or the remote for all menu operations.

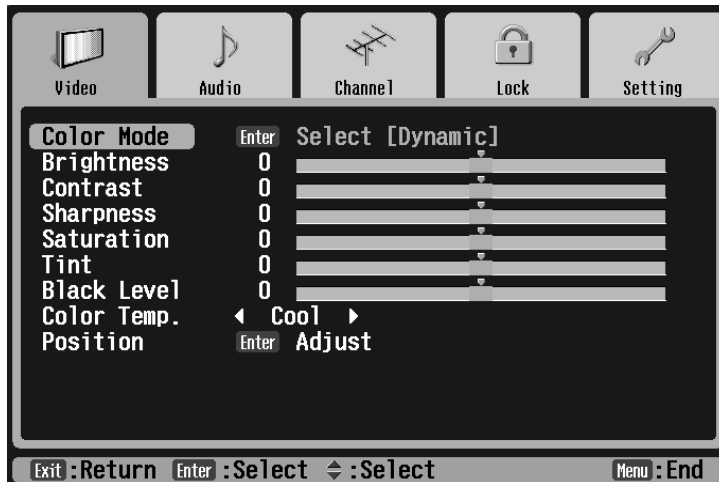

Changing the Color Mode

- 1 Press Enter.
- 2 Press Select ▼ or Select ▲ to choose one of the following, then press Enter:

Note

If the screen color is too warm (red) or cool (blue), you can adjust it with the Color Temperature setting (see page 65).

Dynamic

Best for viewing movies in a brightly lit room. Colors appear warm and vibrant.

Theater

For viewing movies in a darkened room. Colors appear true-to-life; more subtle than Dynamic mode.

Natural

For viewing TV programs in ordinary room lighting.

Custom1 and Custom2

Adjust any of the other settings on the Video menu. The settings you select are used whenever you select Custom1 or Custom 2 using the COLOR button.

Adjusting the Brightness, Contrast, Sharpness, Saturation, Tint, and Black Level

- 1 Press Select ▼ or Select ▲ to highlight the setting, then press Enter.

The menu disappears and the setting selector appears at the bottom of the screen.

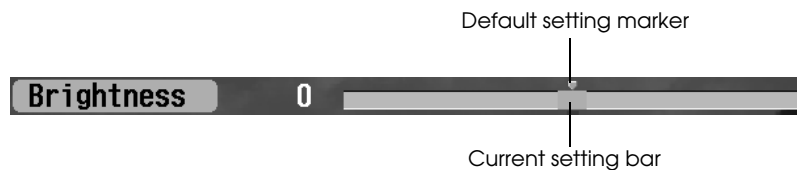

- 2 Press Prev < or Next > to adjust the setting. Press the buttons repeatedly or hold them down. The current setting bar moves and the setting number changes, but the default setting marker stays in position.

The table below describes how the adjustments affect the settings:

Setting	Left side (press Prev <)	Right side (press Next >)
Brightness	Darker	Lighter
Contrast	Less contrast	More contrast
Sharpness	Less sharp	Sharper
Saturation	Less saturated colors	More saturated colors
Tint	More red tones	More green tones
Black Level	Reduces black level	Increases black level

- 3 Press Exit to return to the menus or press MENU to return to your image.

Adjusting the Color Temperature

- 1 Press Select ▼ or Select ▲ to highlight Color Temp..
- 2 Press Prev < or Next > to select one of these settings:
 - Warm
Changes the overall tone to emphasize warm colors, such as gold and brown.
 - Cool
Changes the overall tone to emphasize cool colors, such as blue and green.
 - Medium
Balances the overall tone between warm and cool colors.

Adjusting the Screen Position

- 1 To adjust the position of your image on the screen, press Select ▼ or Select ▲ to highlight Position.
- 2 Press Enter.

The menu disappears and a position selector appears on your image:



Note

To change the screen position, you must be projecting an image on the screen.

- 3 To position the image on the screen, press Select ▼, Select ▲, Prev <, or Next > as necessary. (This doesn't affect the position of the menus.)
- 4 Press Exit when you're finished.

Switching the Component Video Image Quality Setting

If you're viewing 480p broadcasts (EDTV) through an HDTV tuner, you may want to switch the 480p Color Matrix option to the HDTV setting. When watching DVDs, select the DVD setting. Color and image quality is improved for devices connected through the TV's Component Input ports.

- 1 Press the Menu button on the TV panel or the remote control.
- 2 To highlight the Setting menu tab, press Next >.
- 3 Press Enter. The Auto Aspect setting is highlighted.

- 4 Press **Select** ▼ to highlight the 480p Color Matrix setting.



- 5 Press **Prev** < or **Next** > to select DVD (to optimize the quality of DVD images) or HDTV (to optimize the quality of EDTV images).
- 6 Press **Exit** to select another menu or press **MENU** to exit the menu system.

Selecting the Aspect Ratio

Most TV and video signals determine the size of the image on your screen. If your video source is connected to the TV's Video or S-Video port, or if you're watching a TV program through the TV's built-in tuner, you can change the shape of the picture (called the aspect ratio) by pressing the **Aspect** button on the remote control.

Press the **Aspect** button repeatedly to select any one of the screen sizes shown below. The name of the aspect ratio appears in the upper left corner.

Normal is the default size of your video source, if it is in standard 4:3 broadcast ratio.



Full stretches a standard 4:3 ratio image to fit into your 16:9 ratio screen, stretching equally on all sides.

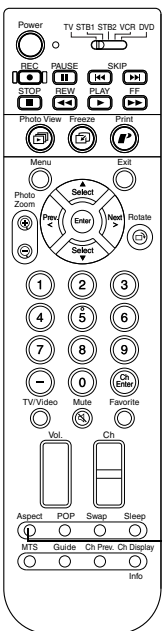

Aspect button

Wide stretches a standard 4:3 ratio image to fit into your 16:9 ratio screen, but the image size stretches increasingly more from the center to the sides.



Zoom enlarges the entire screen and cuts off some of the top and bottom for a closer view. Use **Zoom** when you're watching movies broadcast in Letterbox format so they fit your screen.



Auto lets the TV select a suitable aspect ratio based on the signal it receives. If it can't detect an aspect ratio from the signal, it displays the image using the default option selected in the menu system, as described below.

Selecting the Default Aspect Ratio

You can also use the menu system to select the aspect ratio the TV uses, in case it can't detect the aspect ratio of the signal source:

- 1 Press the **MENU** button on the TV panel or the remote control.
- 2 To highlight the Setting menu tab, press **Next >**.
- 3 Press **Enter**. The Auto Aspect setting is highlighted.



- 4 Press the **Prev <** or **Next >** button to select the desired setting (Normal, Full, Wide, or Zoom).
- 5 Press **Exit** to select another menu or press **MENU** to exit the menu system.

Adjusting the Sound

To turn the TV speaker volume up or down, use the Vol. up and down buttons on the TV panel or remote control. To mute the sound, press the Mute button on the remote control.

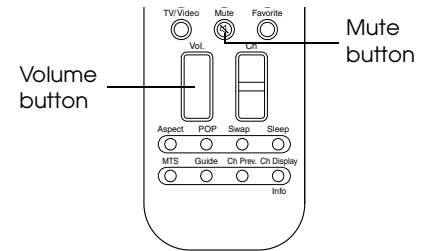

Note

If you connect headphones to the TV, the TV speaker sound shuts off. You can press Mute to mute the headphone audio too.

If you connected your TV to an external amplifier and additional speakers (see page 29), the Vol. button controls the sound from those speakers too.

If you connected headphones to the Headphone connector on the TV front panel, you can still hear sound if the Speaker setting is turned off.

To adjust the bass, treble, or balance of the sound from your TV speakers, you can change the Audio settings in the menu system. You can also turn off the TV speakers or the simulated surround sound feature.

- 1 Turn on a program that includes sound so you can check the results of your adjustments.
- 2 Press the Menu button on the TV panel or the remote control.
- 3 To highlight the Audio menu tab, press Next >.
- 4 Press Enter. The Bass setting is highlighted.



- 5 Press Select ▼ or Select ▲ to highlight the Bass, Treble, or Balance setting.
- 6 Press Enter. The menu disappears and a selector appears on the bottom of the screen.

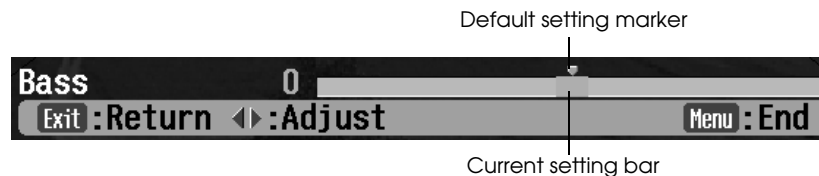

Press Prev < or Next > to move the setting higher or lower. Press the buttons repeatedly or hold them down. The current setting bar moves and the setting number changes, but the default setting marker stays in position. Press Exit to return to the menus or press Menu to return to your image.

- 7 To turn the simulated Surround feature or the Speaker on or off, press Prev < or Next > to toggle between the two options.
- 8 Press Exit to select another menu or press Menu to exit the menu system.

Using TV Features

Your TV provides various features to enhance your viewing experience, as described in these sections:

- “Printing What You See on the Screen” on page 69
- “Using Picture-Outside-Picture (POP)” on page 71
- “Using Channel Zapping” on page 73
- “Turning On Closed Caption Display” on page 75
- “Selecting an Alternate Audio Track or Language” on page 75
- “Automatically Shutting Off the TV” on page 76

Printing What You See on the Screen

You can “freeze” and print any video image that you see on your TV screen, such as a scene in a movie or sporting event on TV (except from sources connected to the DVI or PC port). Then you can print the image, if you like. Since you cannot save the image as a digital file, be sure to print it if it’s something important that you want to keep.

- 1 While you’re viewing a program or movie, press the **Freeze** button on the TV panel or remote control. You see the Freeze window:

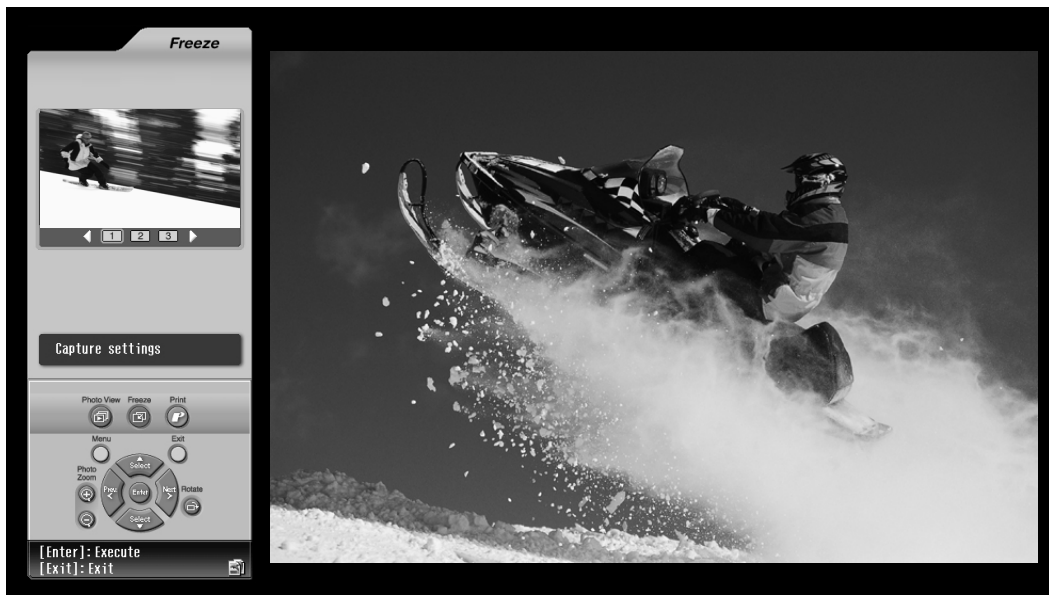

The program or movie keeps running on the right and the frozen image is shown on the left.

- 2 Freeze captures 3 different images taken 40 milliseconds apart so you can choose the one you like best.

To view the 3 frozen images, press **Prev. <** or **Next >**.

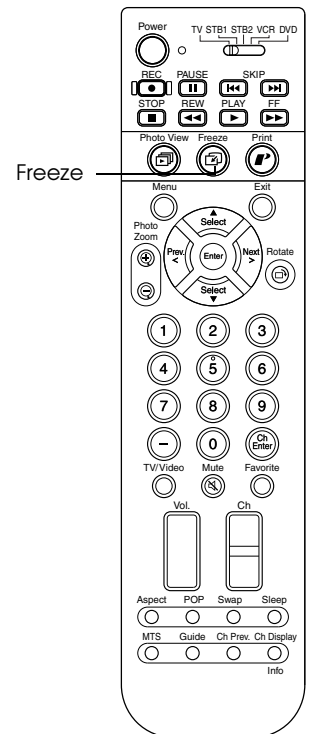

(To freeze additional images, press the **Freeze** button again. The previously frozen images are erased.)

Note

For most video images, freezing the display in the standard mode is sufficient. However, if you're freezing an image with text (such as a recipe) or freezing an image from a DVD player that uses progressive output, you may get better results by changing the capture mode. See page 71 for instructions.

- 3 To enlarge the selected image, press **Enter**. To return to the Freeze window, press **Exit**.
- 4 To print the currently displayed image, press the **Print** button on the TV panel or remote control.

You see the Print Settings screen. (The current program or video image keeps running on the right.)

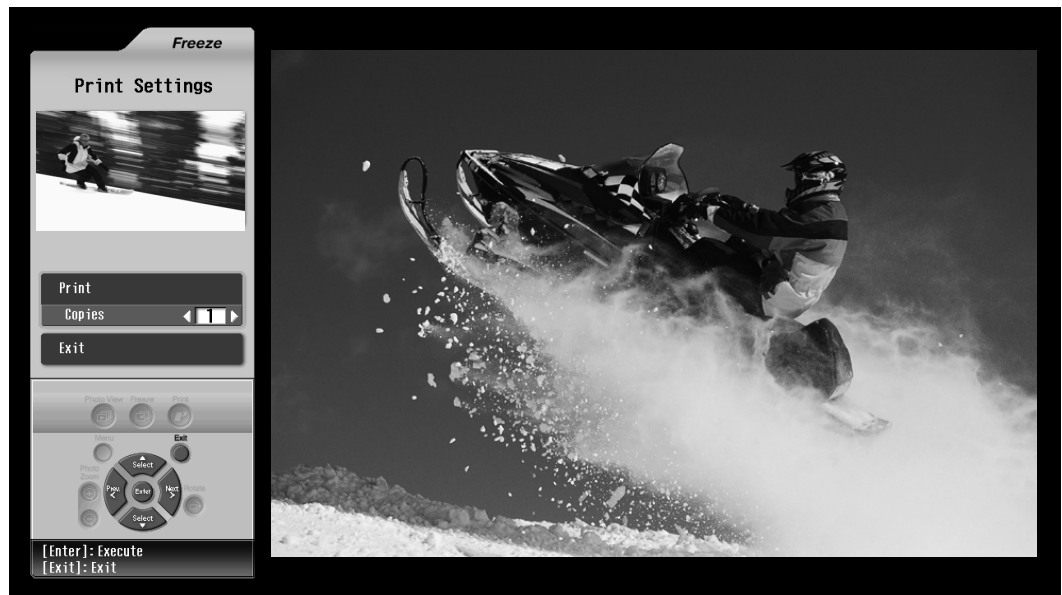

Note

Make sure you have paper loaded in the printer. For instructions, see page 86.

- 5 To select the number of printed copies you want, press **Prev.** < or **Next** >.
- 6 Press **Enter**. Your image is sent for printing.

During printing, the **Printer** light flashes. When printing is finished, the **Printer** light turns off.

- 7 To freeze another image for printing, repeat steps 1 through 6. You can send up to 3 frozen images for printing at one time.
- 8 To exit the Freeze menu, press the **Exit** button on the TV panel or remote control.

To monitor or cancel your print job, see page 91.

If you see a printing error message, select **Yes** to check for the problem. Then follow the on-screen instructions to solve the problem and continue printing. For additional help, see page 115.

When you're finished printing, remove the borders from the edges of your photo by bending them back and forth and tearing them off.

Changing the Capture Settings

If you're freezing images containing text or images from a DVD player that uses progressive output, you may get better results by changing the capture method, as described below.

- 1 Press the **Freeze** button.
- 2 Press **Select ▼** to highlight **Capture settings** and press **Enter**. You see the **Capture Settings** screen:

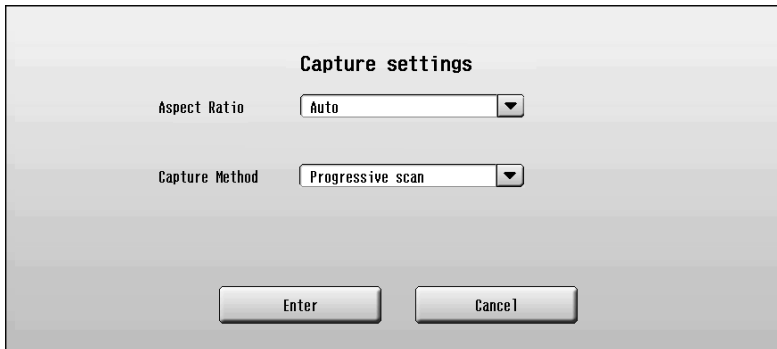

- 3 To change the aspect ratio of the image you're freezing, press **Enter**. Then press **Select ▼** to highlight **16:9** and press **Enter**.
- 4 To change the capture method, press **Select ▼** to highlight **Capture Method** and press **Enter**. Then press **Select ▼** to highlight **Progressive scan** and press **Enter**.
- 5 When you're finished, press **Select ▼** to highlight **Enter** and press **Enter**.
- 6 Press **Exit** to return to normal viewing.
- 7 Press **Freeze** to freeze an image using the new settings, as described on page 69.

Using Picture-Outside-Picture (POP)

You can view images from two channels or sources at once using POP (Picture-Outside-Picture). This lets you check on a sporting event on TV while you watch a movie, for example. You can also watch TV, a DVD, or another source while you view photos from a digital camera card or an external CD.

You cannot display images in POP mode using equipment connected to input sources in these combinations:

- Component Inputs 1 and 2
- Component Inputs 1 or 2 and DVI or PC
- DVI and PC

The first video source you select for viewing in POP is the main source. You'll be able to hear the audio only from this source, so select the source you'd like to listen to first.

- 1 Press the **TV/Video** button on the TV panel or remote control to select your main source (such as **Video 1** for the DVD player). You'll hear audio only from this source when you turn on POP.

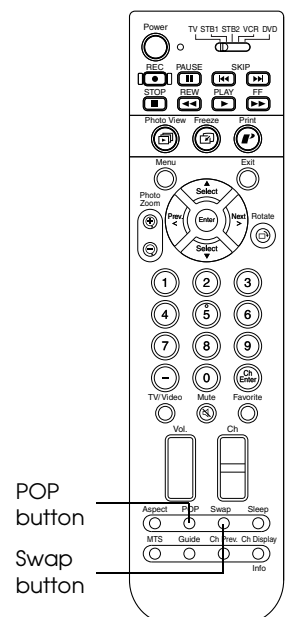

Note

If you're watching a TV station and have no second video source running, the next TV channel is automatically selected as the second source.

If you want to view photos on a digital photo card or CD while using POP, insert the card or CD first. The photo viewer screen appears. Now press the POP button on the remote control. (You can only view images in this mode; you can't print.)

The photo viewer window remains on the right side of the screen when you're using POP. When you press the Swap button, the red outline moves from source to source.

To exit the photo viewer when its window is outlined in POP mode, press the POP button, press the 5 button, and press Enter.

Note

If you're viewing the photo viewer in the right POP window, press Swap to select the other source before resizing the window. You can't resize the photo viewer window directly in POP mode.

- 2 Press the POP button on the remote control. The image from the first source appears on the left and the image from the second source appears on the right.

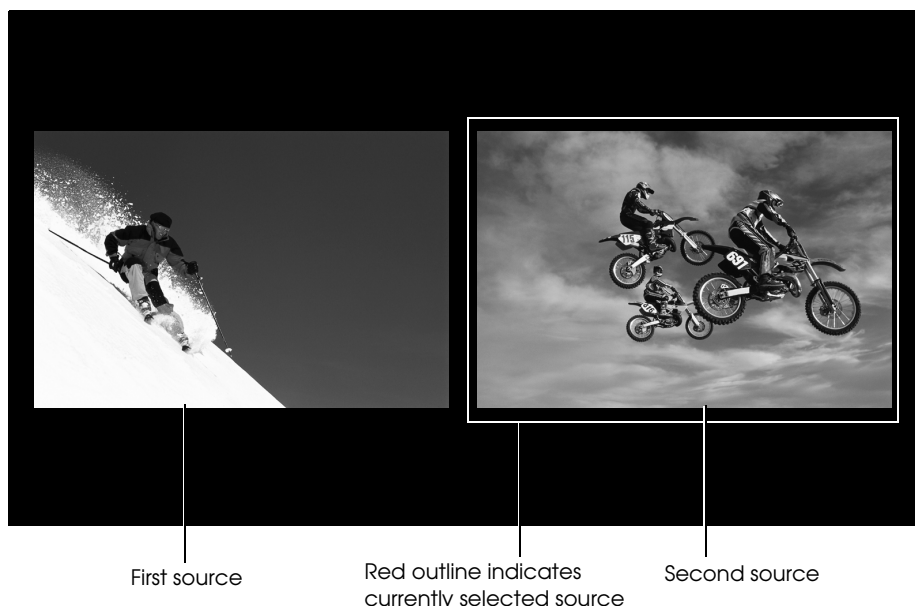

- 3 Press the TV/Video button to change the second source, if necessary.

Here's how to select a new source in POP:

- 1 Press the Swap button on the remote control to choose the left or right source. A red outline appears around the current selection (always on the right).
- 2 Press the TV/Video button to change the source. If you're using the photo viewer, press Photo Zoom + or - to select an image.

To resize the POP windows, press Swap to select the source, then press Next > to enlarge its window or Prev. < to reduce it. The other window is automatically resized to fit the screen.

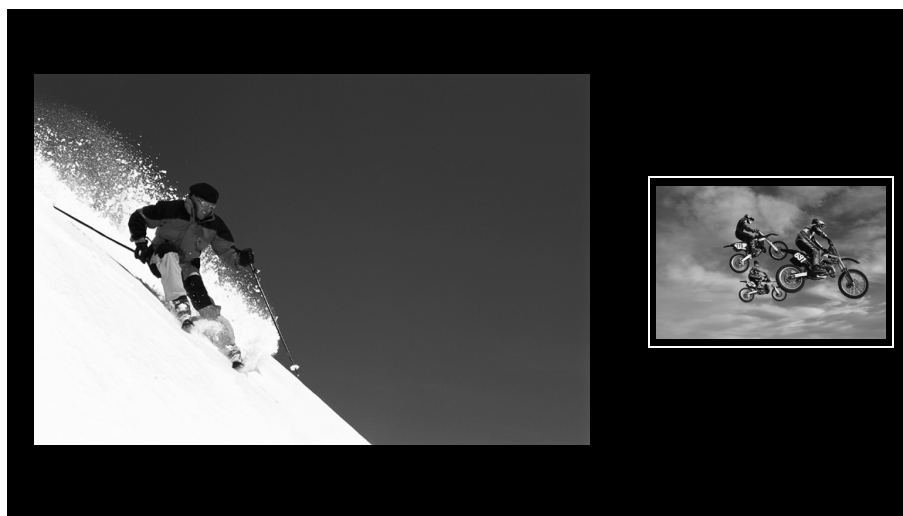

To exit POP, make sure the source you want to continue viewing is selected (if necessary, press Swap to select it). Then press POP twice or press Exit.

Using Channel Zapping

Channel zapping lets you get a quick look at programs broadcast on up to seven additional channels while you're watching a TV program on an eighth channel. If you see a different channel that you want to watch, you can make it your main program.

To use channel zapping, you must be watching a cable or broadcast program received through the ANT 1 port (as shown on page 17). The factory-installed jumper cable that connects the ANT 2 and RF Output ports also has to be in place. Follow the steps below to turn off the ANT 2 port; this frees the necessary tuner.

Note

You also need to turn off the V-Chip feature to use channel zapping. See page 55 for instructions.

Turning Off the ANT 2 Port

- 1 Make sure the jumper cable connecting the ANT 2 and RF Output ports is still installed on the back of your TV.
- 2 Press the **Menu** button on the TV panel or remote control. You see the Video menu.



- 3 Press **Next >** to highlight Channel, then press **Enter**.
- 4 Press **Select ▼** to highlight Use of Ant. 2, then press **Next >** to select OFF.



- 5 Press **Menu** to exit the menu system.

Zapping Channels

The first channel you select in channel zapping is the main channel. You'll be able to hear the audio only from this channel, so select the channel you'd like to listen to first.

- 1 Press the POP button on the remote control. You see the POP (Picture-Outside-Picture) screen display (two images at once).
- 2 Press the POP button again.

You see the channel zapping window with your main channel on the left. The next 4 and previous 2 channels gradually fill windows on the right side of the screen with a frozen image from each channel. The main zapped channel is outlined in red at the top.

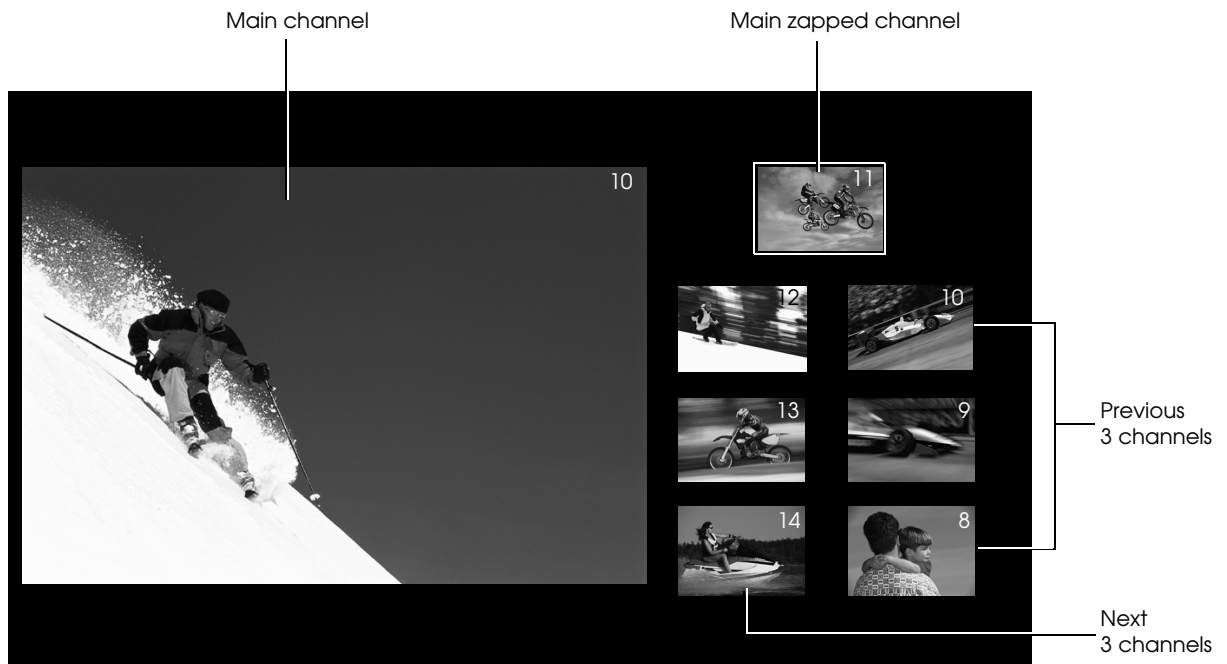
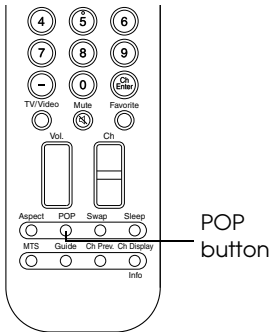

Here's how to control the zapped channels:

- To view the zapped channel at the top as your main channel on the left, press the **SWAP** button.
- To make the next zapped channel your main zapped channel, press **Ch +** or **Select ▲**. The channels rotate into position. When you see the channels you want, press **Enter** to stop channel rotation.
- To make the previous zapped channel your main zapped channel, press **Ch -** or **Select ▼**. The channels rotate into position. When you see the channels you want, press **Enter** to stop channel rotation.

To return to single channel viewing, press the POP or Exit button. (To view two channels at once, press POP again and follow the steps on page 71.)

Turning On Closed Caption Display

You can turn on closed caption display so you can read dialogue or station information transmitted along with certain programs. You can also turn on an option that displays closed captions whenever you press the **Mute** button on the remote control. That way, you won't miss any dialogue when you've muted the sound.

- 1 Press the **MENU** button on the TV panel or the remote control.
- 2 To highlight the Setting menu tab, press **Next >**.
- 3 Press **Enter**. The Auto Aspect setting is highlighted.



- 4 Press **Select ▼** to highlight the Closed Caption setting.
- 5 Press **Prev <** or **Next >** to select one of the following options:

CC1, CC2, CC3, or CC4

Displays closed captions of the program's dialogue and sound effects.

TEXT1, TEXT2, TEXT3, or TEXT4

Displays closed captions of the network and station information.

MUTE ON

Displays closed captions whenever you press the **Mute** button on the remote control.

OFF

Turns off closed captions.

- 6 Press **Exit** to select another menu or press **Menu** to exit the menu system.

Selecting an Alternate Audio Track or Language

When the channel you are viewing provides alternate audio tracks, you can select a different track to hear sound in Mono (the default is Stereo) or listen to a different language.

To select audio modes, press the **MTS** (Multichannel Television Stereo) button on the bottom of the remote control. The current mode appears in the upper left corner of the screen. Press the **MTS** button to change the mode as necessary.

Note

Not all the closed caption modes may be available for your program. Select CC1 or TEXT1 first to see if they work.

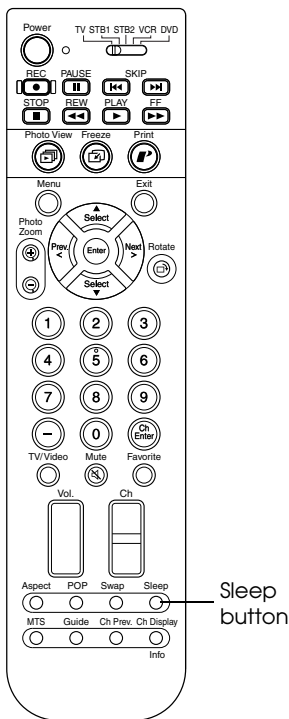

Automatically Shutting Off the TV

You can set up the TV to shut off automatically in case you fall asleep or want to control how long it stays on. You can set the TV to go into “sleep” mode after 30, 60, or 90 minutes or you can set it to turn off automatically after 30 minutes if it receives no signal input.

Putting the TV Into Sleep Mode

- 1 Press the **Sleep** button on the remote control. SLEEP OFF appears in the upper left corner of the screen.
- 2 Press the **Sleep** button again to select one of the following options:
 - SLEEP 30min
 - SLEEP 60min
 - SLEEP 90min
- 3 To check how much time is left before the TV enters sleep mode, press the **Sleep** button. If less than 3 minutes are left, the time display remains on the screen. Press **Sleep** again if you want to change the sleep time or turn off sleep mode.
- 4 After the selected time has elapsed, the TV screen goes blank and the **POWER** light flashes orange. When the **POWER** light stays lit orange, the TV is in sleep mode.

To turn the TV back on, press the **POWER** button on the TV panel or remote control.

Setting Up Auto Shutdown

- 1 Press the **Menu** button on the TV panel or the remote control.
- 2 To highlight the Setting menu tab, press **Next >**.
- 3 Press **Enter**. The Auto Aspect setting is highlighted.
- 4 Press **Select ▼** to highlight Auto Shutdown.



- 5 Press **Prev. <** or **Next >** to select **ON**.
- 6 Press **Menu** to exit the menu system. If there is no signal input after 30 minutes, the TV shuts off.

Viewing, Printing, and Saving Photos

You can use the digital photo card slots and printer built into your TV, and the external CD-R/RW drive, to view, print, and save digital photos, as described in these sections:

- “Viewing Photos on a Digital Photo Card or CD” below
- “Printing Photos” on page 86
- “Saving Photos to CD” on page 92

Viewing Photos on a Digital Photo Card or CD

You can view photos on your TV screen from a compatible digital photo card or a CD. You can also enlarge and rotate your photos and view them in a slide show.

- “Compatible Photos and File Structure (Photo Card)” below
- “Inserting a Photo Card” on page 78
- “Compatible Photos and File Structure (CD)” on page 80
- “Inserting a CD” on page 80
- “Enlarging and Rotating Photos” on page 83
- “Viewing a Slide Show” on page 84

Compatible Photos and File Structure (Photo Card)

Make sure your photo card uses the file structure and naming conventions defined in the DCF standard so the photo viewer can display your photos. Most digital cameras automatically format the files this way, but if you copy photos to the photo card using another device, you may need to set up this structure yourself.

- The folder structure must be:

`D:\DCIM\`
or
`D:\DCIM\123abcde\`

where *D:* is the drive letter of your card reader, and it contains a DCIM folder. Your photos may be in the DCIM folder or in a folder beneath it. Any folders beneath the DCIM folder must be no more than 8 characters long, usually three numbers followed by up to 5 alphabetic characters, such as 100epson.

- The photo files must be in JPEG format and named:

`abcd1234.jpg`

where *abcd1234* is a file name 8 characters long, beginning with 4 letters and ending with 4 numbers higher than 0000, such as `epsn0001.jpg`.

Note

Your TV can view photos in JPEG (Joint Photographic Experts Group) format on cards that are DCF (Design rule for Camera File system) version 1.0 compliant.

You cannot use a Microdrive™ disc or a Memory Stick PRO™ or PRO Duo™ card in your TV.

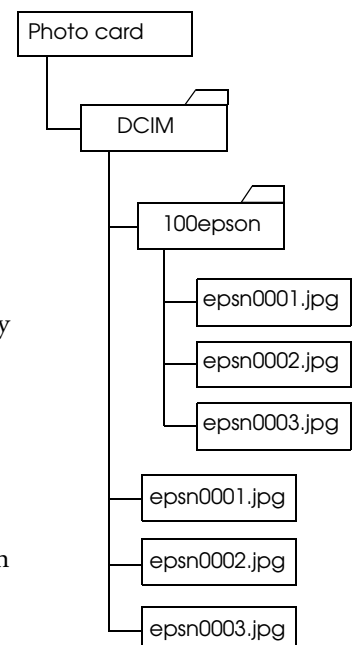

Note

The photo viewer cannot display, enlarge, or print TIF images. You see only the  icon on the viewer screens for TIF images. You can write TIF images to a CD-R/RW and view them on your computer, however.

- The photo files must contain a time stamp, so the slide show can display the files in time stamp order.
- The photo files should contain thumbnail data, such as that included in Exif format JPEG files, to speed up display of the files in the photo viewer.

Inserting a Photo Card

- 1 Make sure the TV is turned on and the POWER light is green and not flashing. Also make sure the CARD and Printer lights are off.
- 2 Insert your photo card in the appropriate slot on the TV's front panel. The CARD light flashes orange as the TV reads the data on the card.

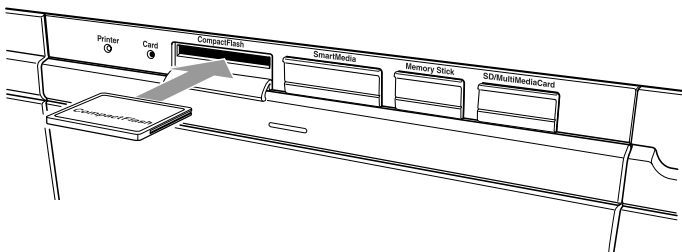

CompactFlash® card

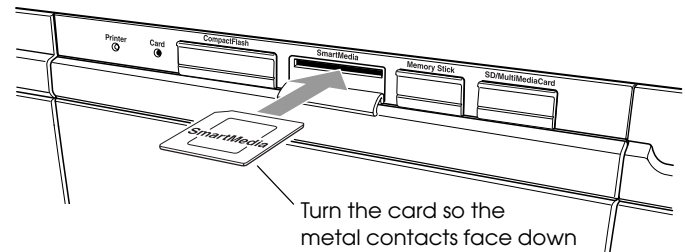

SmartMedia® card

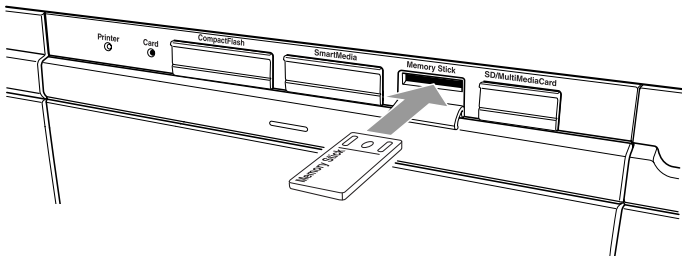

Memory Stick®

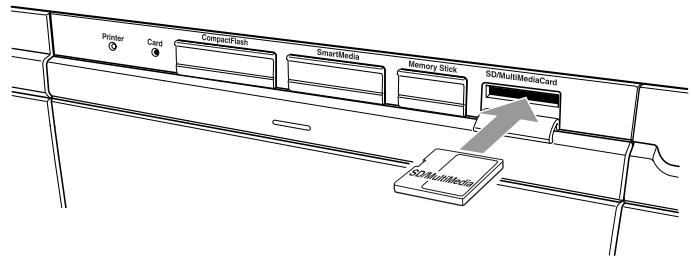

SD/MultiMediaCard™

Note

Memory Stick PRO and PRO Duo cards are not supported at this time.

- After a few seconds, the Photo screen appears. It displays the photos on your card and outlines the first one in gold:



- If you inserted more than one photo card, the photos on the card you inserted first appear on the screen.

To switch to the photos on another card, press the 1 button. (Or press Menu, press Select ▼ or Select ▲ to highlight Photo Source, then press Enter.)

The Photo Source menu on the left is opened. Press Select ▼ or Select ▲ to highlight the card you want to view and press Enter.

- Follow the instructions in these sections to view or print your photos:
 - “Enlarging and Rotating Photos” on page 83
 - “Viewing a Slide Show” on page 84
 - “Printing Photos” on page 86
- To exit the photo viewer, press the 5 button or press Menu, highlight Exit viewer, and press Enter.
- Wait for the CARD light to shine green or turn off, then remove your digital photo card(s).

Note

If the photo viewer doesn't come up automatically, press the Photo View button on the TV panel or remote control.

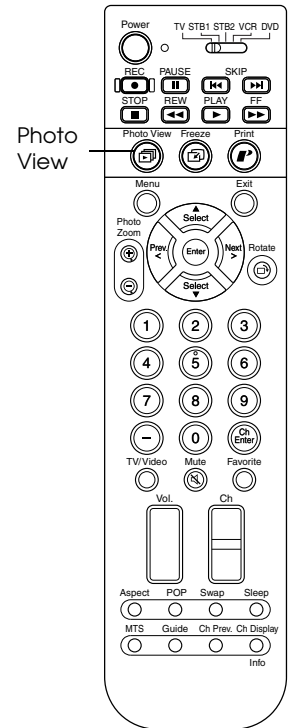

Note

You can select the menus on the left of the screen by pressing the Menu button, highlighting the menu, and pressing Enter. You can also select them by pressing the number button for the menu, such as 1 for the Photo Source menu or 2 for the Slide Show menu.

Caution

Don't remove a card from the slot when the Card light is flashing or you may damage the card.

Compatible Photos and File Structure (CD)

If you create a CD-R/RW of your photos using a computer, make sure that you use the file structure and naming conventions defined in the DCF standard so the photo viewer can display your photos. Your CD-R/RW must contain folders and files using the following structure and format:

- The folder structure must be:

D:\nnnnnnnn

where *D*: is the drive letter of your CD drive and *nnnnnnnn* is a folder up to 8 characters long, such as \pictures. Any folders beneath the first level folder must also be no more than 8 characters long.

- The photo files must be named:

nnnnnnnn.jpg

where *nnnnnnnn* is a file name up to 8 characters long (consisting of alphanumeric characters and the *~* and *_* symbols), such as photo001.jpg. The file must be in JPEG format.

- The photo files must contain a time stamp, so the slide show can display the files in time stamp order.
- The photo files should contain thumbnail data, such as that included in Exif format JPEG files, to speed up display of the files in the photo viewer.

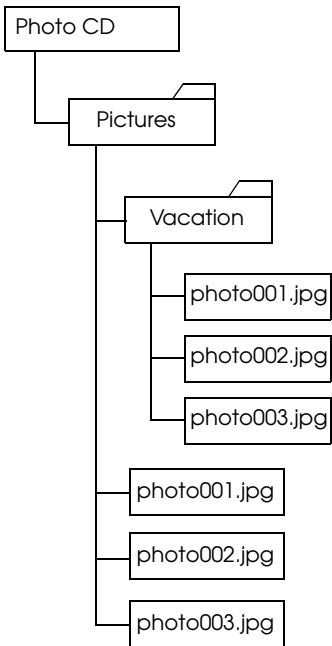

Note

The photo viewer cannot display, enlarge, or print TIF images. You see only the  icon on the viewer screens for TIF images. You can write TIF images to a CD-R/RW and view them on your computer, however.

You cannot use the TV to write photos to a CD-R/RW disc that was previously written to by a computer. You can view and print photos from these discs, but you cannot write new photos to them using your TV. This is because your TV and computer use different methods for writing files. When you want to write photos to a CD-R/RW, use a new, blank disc.

Inserting a CD

Before you view photos on a CD, make sure you've connected the external CD-R/RW drive that came with your TV. See page 15 for instructions.

Follow these steps to insert a CD-R/RW in your external CD-R/RW drive:

- 1 Make sure the TV is turned on and the **POWER** light is green and not flashing.
- 2 Press the eject button on the drive to open the tray.

- Place your CD-R/RW on the tray with the label side facing up. Make sure the disc lays flat in the tray.

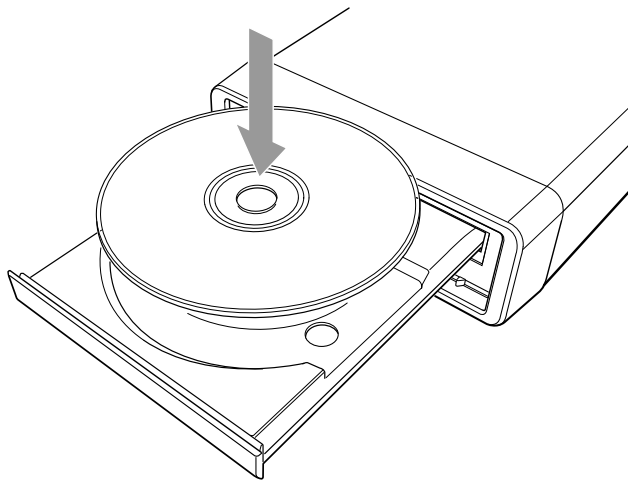

- Press the eject button again to close the tray.
- Press the Photo View button on the TV panel or remote control. The Photo screen appears:

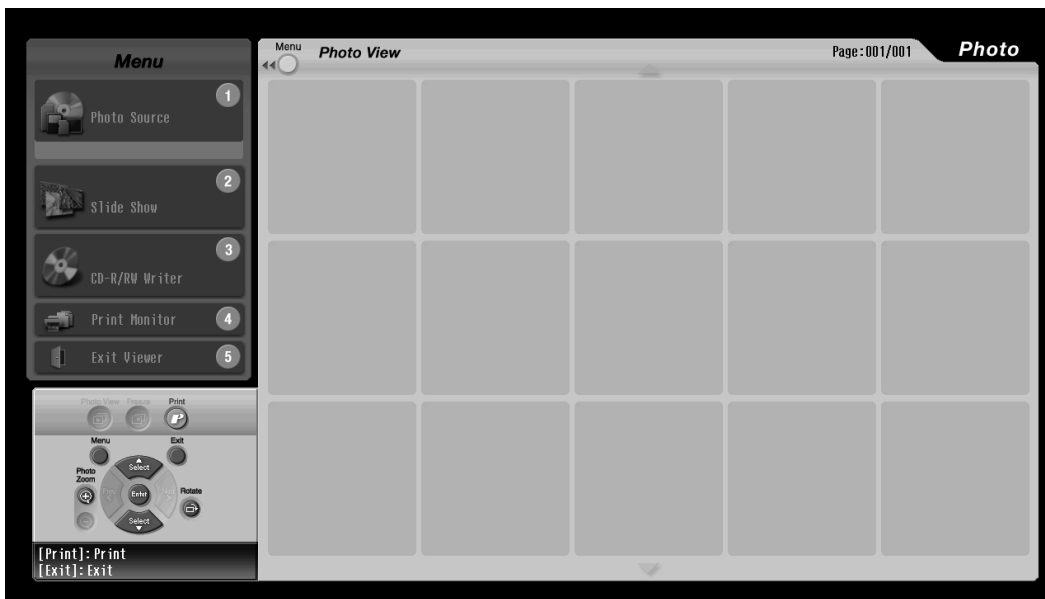

Caution
Always use the eject button to open and close the tray. Pushing in the tray may damage the drive and your disc.

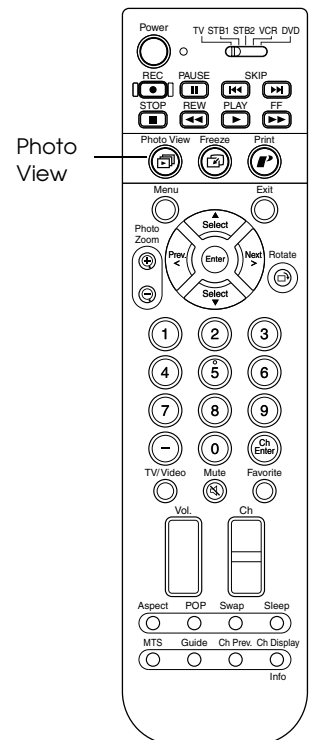

- Press the 1 button. (Or press the Menu button, then press Enter.)
The Photo Source menu on the left is opened.

Note

If you don't see your folders, your drive may not be ready. Wait a moment and repeat step 6.

If you still don't see your folders, your disc may contain the wrong folder or file format. See page 80 for details.

- Press **Select ▼** to highlight CD-R/RW (if necessary) and press **Enter**. You see the CD folders in the Photo View screen:

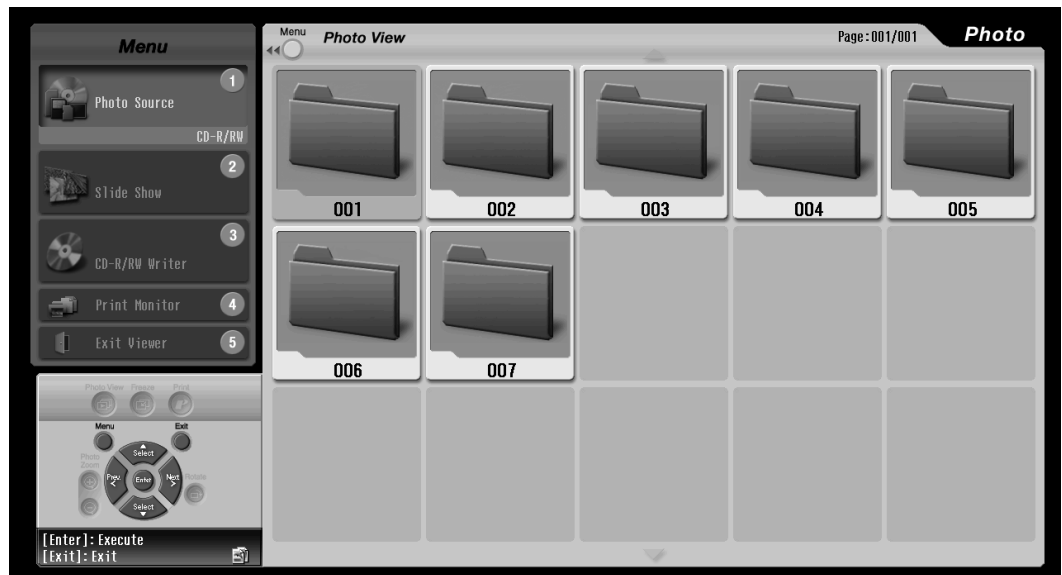

- Select a folder by pressing the **Prev. <**, **Next >**, **Select ▼**, or **Select ▲** button. Then press **Enter**. The folder opens and the photos within it appear in the Photo View screen:

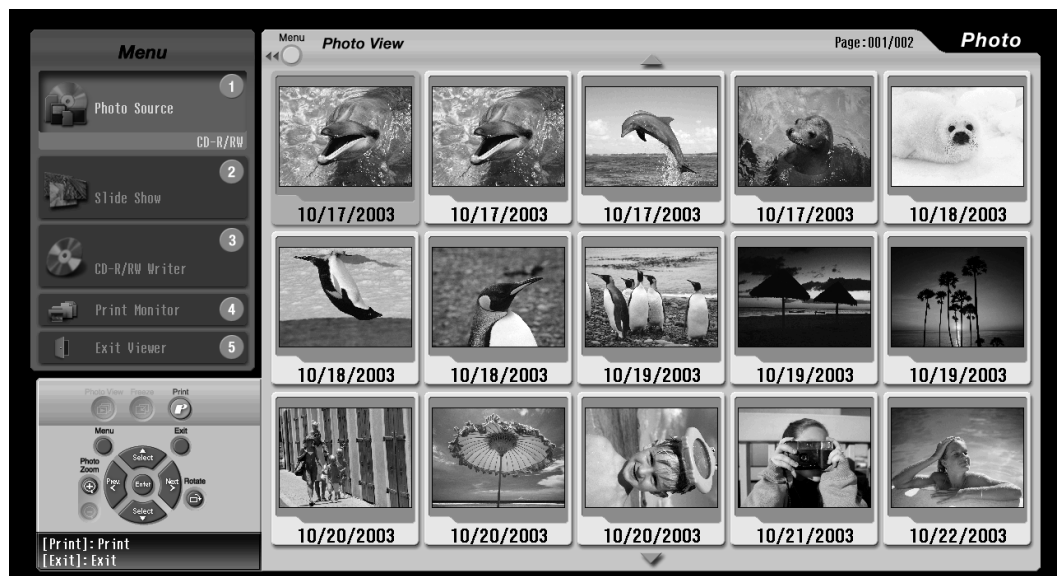

- To view the photos in a different folder, press **EXIT**. Then repeat step 8.
- Follow the instructions in these sections to view or print your photos:
 - “Enlarging and Rotating Photos” on page 83
 - “Viewing a Slide Show” on page 84
 - “Printing Photos” on page 86
- To exit the photo viewer, press the 5 button or press **Menu**, highlight **Exit viewer**, and press **Enter**. Press the eject button on the CD-R/RW drive to remove your disc.

Enlarging and Rotating Photos

After inserting your photo card or CD, you can enlarge the photo view. You can also zoom in on parts of the photo or rotate it so you can view it correctly. The rotated position is retained until you remove the card or CD. You can also print a photo after zooming in on it, effectively enlarging and cropping the printed photo.

- 1 If necessary, press **Menu** to move to the Photo View screen.
- 2 Select a photo by pressing the **Prev. <**, **Next >**, **Select ▼**, or **Select ▲** button.
- 3 Press the **Enter** button on the TV panel or remote control. The current photo is enlarged.

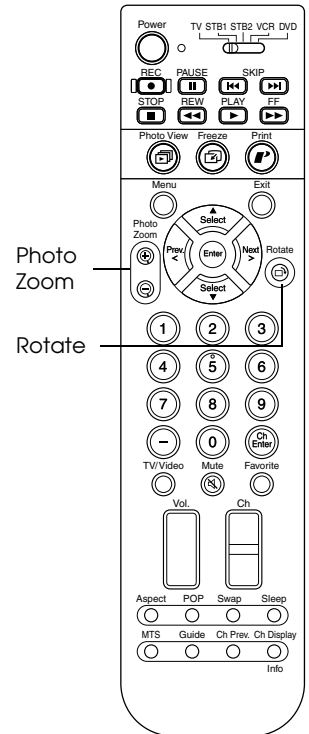

- 4 To rotate the photo, press the **Rotate** button on the remote control. Press it again to keep rotating.
- 5 To zoom into the photo, press the **Photo Zoom +** button. Press **Photo Zoom -** to zoom out. Use the **Prev. <**, **Next >**, **Select ▼**, and **Select ▲** buttons to select the part of the photo you want to view.
- 6 To select another photo, press **Exit** or use **Photo Zoom -** to zoom all the way out. Then use the **Prev. <**, **Next >**, **Select ▼**, or **Select ▲** button to select the next photo.
- 7 To return to normal photo viewing, press the **Exit** button on the TV panel or remote control.

Note

You can't rotate an image when it is zoomed. Press **Photo Zoom -** or **Exit** to return the image to normal size, then press **Rotate**.

Note

To move between the Menu and Slide Show sides of the screen, just press Menu.

Caution

Don't remove a card from the slot when you're viewing a slide show or you may damage the card. Wait until the slide show is finished and the Card light shines green (or is off) before removing the card.

Note

To print a photo when you're viewing it in Slide Show mode, press the Print button. Then follow the instructions on page 86 to print it.

Note

If you choose the option for selecting photos individually right after inserting a card, all the photos are automatically selected.

Viewing a Slide Show

You can view your photos automatically, for a few seconds each, by running a slide show. You can view all the photos or just selected ones.

- 1 Press the 2 button. (Or press Menu, press Select ▼ or Select ▲ to highlight Slide Show, and press Enter.)

The Slide Show menu on the left of the screen is opened.

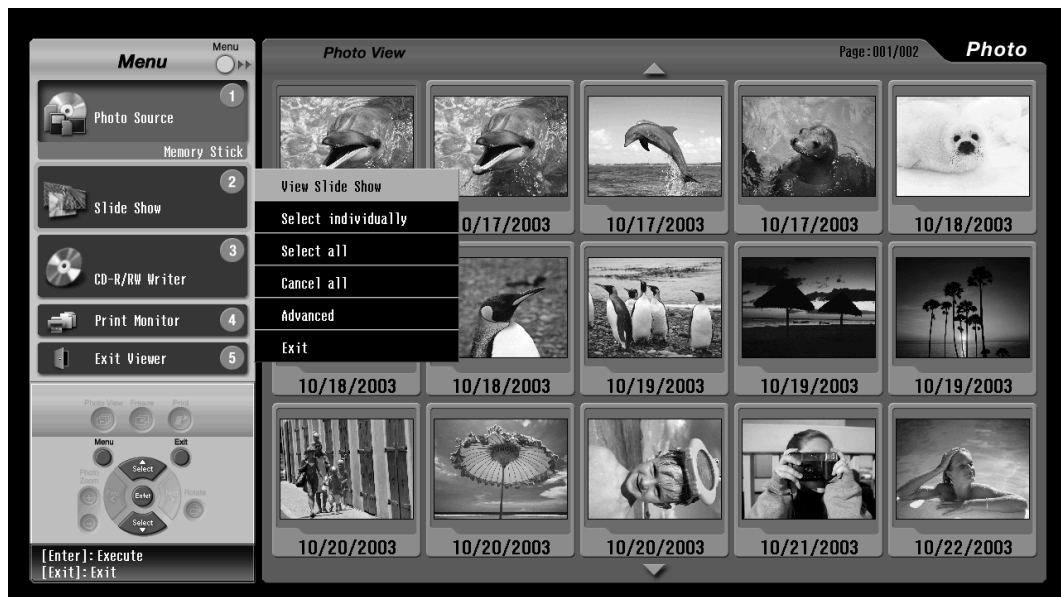

- 2 To view all your photos in a slide show, press Enter to select View Slide Show.

The first photo is enlarged and appears on the screen. It displays for 3 seconds, then the next photo is displayed.

- 3 To pause the slide show, press Enter. The || icon appears on the screen. To resume, press Enter again.
- 4 To end the slide show, press Exit.

Selecting Photos for a Slide Show

If you want to select your favorite photos for a slide show, follow these steps:

- 1 Press the 2 button to open the Slide Show menu.
- 2 Do one of the following:
 - To view most of the photos on your card, press Select ▼ to highlight Select all and press Enter. Your photos appear with checkboxes, indicating that they are selected for inclusion in the slideshow. You can deselect any photos you don't want to view.
 - To view only a few photos on your card, press Select ▼ to highlight Cancel all and press Enter. None of your photos appear with checkboxes; you can select only those you want to view.

- 3 To select or deselect a photo, press Prev. <, Next >, Select ▼, or Select ▲ to highlight it, then press Enter. (A checkmark appears if the photo is selected.)



- 4 When you're ready to run the slide show, press the 2 button, then press Enter to select View Slide Show.
- 5 To end the slide show, press Exit.

Changing the Slide Show Settings

- 1 To change the way your slide show plays, press Exit to stop the slide show, if necessary. Then press the 2 button and select Advanced from the Slide Show menu. You see the Advanced Settings window:



- 2 Slides display at 3 second intervals. To lengthen the interval, press Next > to change the Transition speed setting from 3 to 10 seconds. (Press Select ▼ or Select ▲ to highlight Transition speed, if necessary.)
- 3 Slide shows play continuously until you stop them. To set them to play once and stop on their own, press Select ▼ to select Playback and press Enter. Press Select ▼ to select One cycle and press Enter.
- 4 When you're finished, press Select ▼ to highlight OK and press Enter. You return to the menu screen.

Printing Photos

Once you've viewed your photos on a digital photo card or CD—or captured a video image using the Freeze button—follow the steps in these sections to print it.

- “Loading Paper” below
- “Selecting a Photo and Printing It” on page 89
- “Monitoring or Cancelling Your Print Jobs” on page 91

Loading Paper

You can purchase Photo Printing Packet number V13H151010 containing 50 sheets of paper and an ink cassette from your dealer or Epson. Call (800) 873-7766 or visit the Epson Store at www.epsonstore.com (U.S. sales only). In Canada, please call (800) 463-7766 for dealer referral.

Follow these steps to load up to 20 sheets of paper in the printer's paper cassette:

- 1 Press and release the printer cover latch to open the cover.

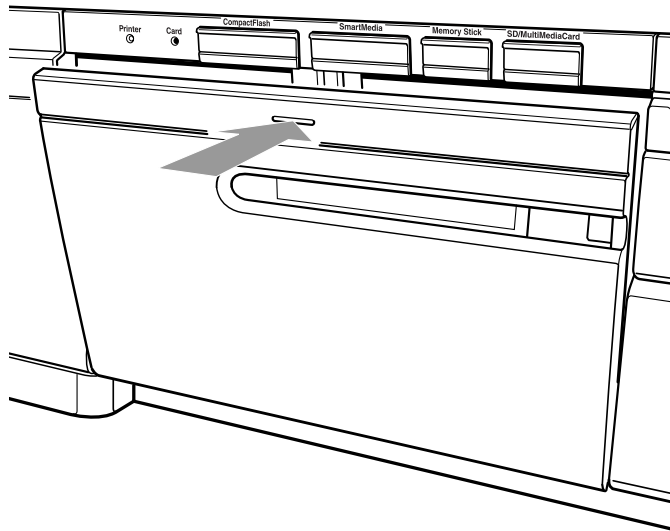

2 Grasp the paper cassette and pull it all the way out of the printer.

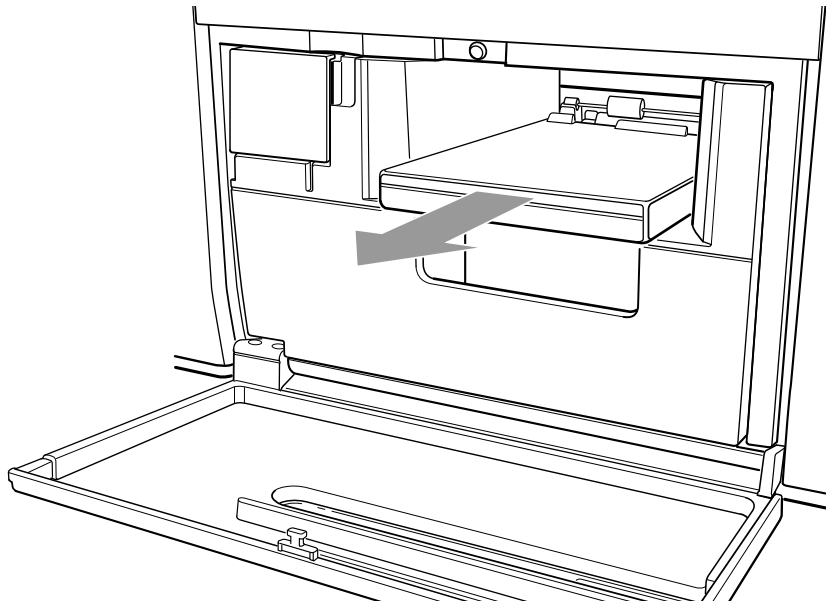

3 Open the paper cassette lid.

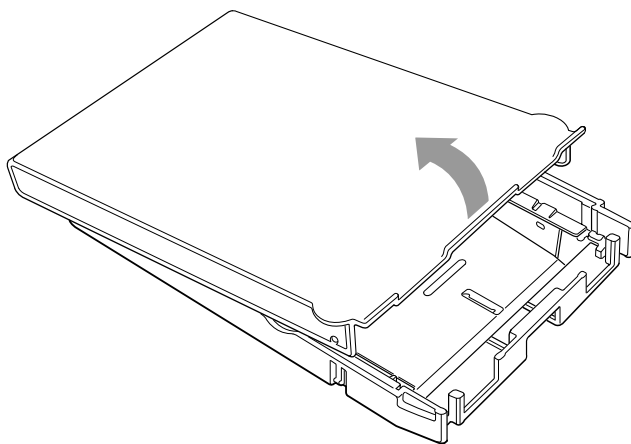

Caution

Don't remove the perforated borders on the paper before you print. The paper may jam or the printer may malfunction when it loads the paper.

Also, don't touch the printable (shiny) surface of the paper. Oil from your hands may cause the paper to discolor.

- 4** You can load up to 20 sheets of paper. Position the paper with the shiny side face up, with the wide bordered edge facing the hinge of the cassette, and the narrow bordered end facing the open end of the cassette.

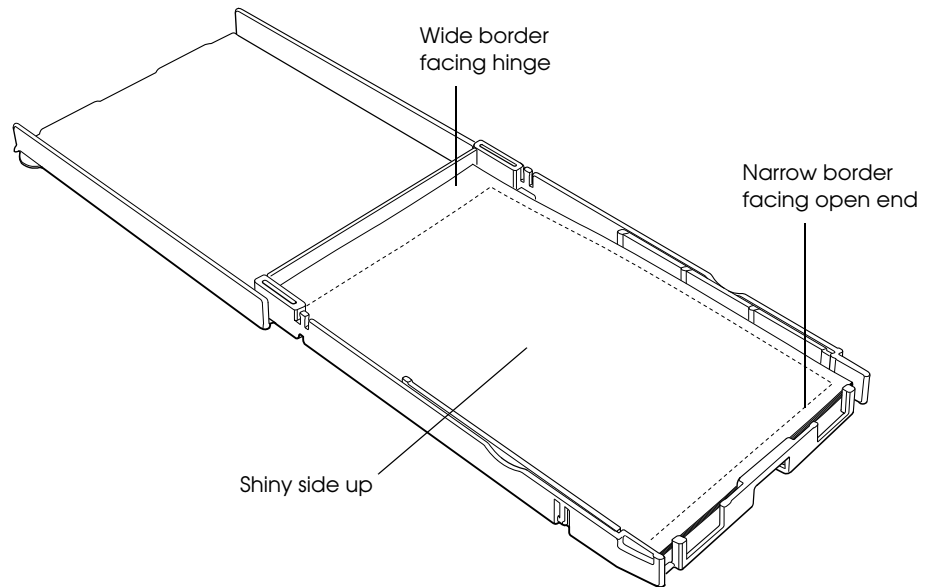

- 5** Close the cassette lid and press it until it clicks shut.

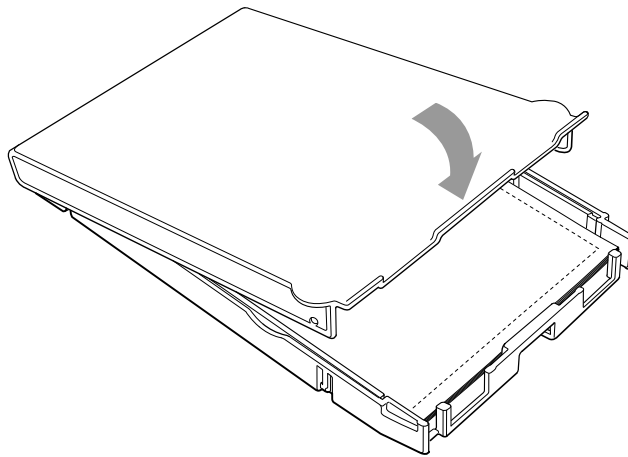

- Slide the cassette into its slot, open end first. Push it in until it clicks into place.

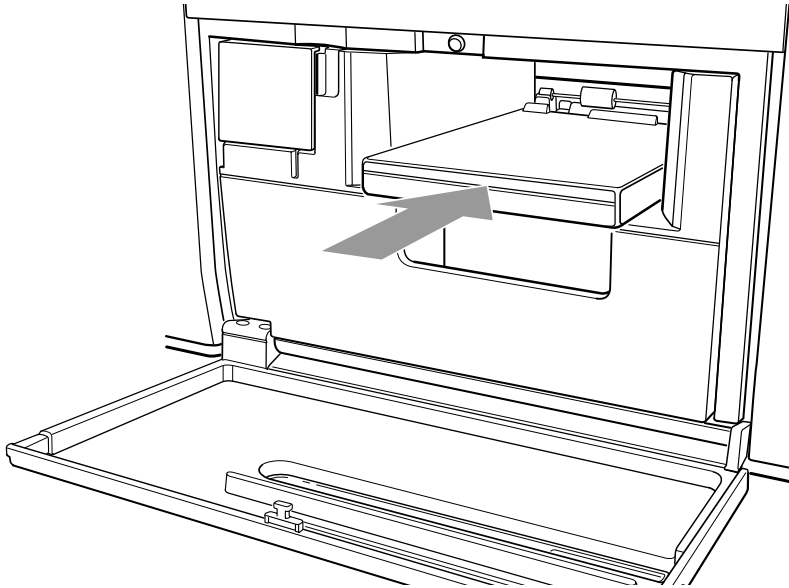

- Close the printer cover.

Selecting a Photo and Printing It

You can print one photo at a time from a digital photo card or CD-R/RW.

If you haven't yet inserted your photo card or CD, insert it. The photo viewer starts automatically. (If it doesn't start, press the Photo View button on the TV panel or remote control.)

- Press Prev. <, Next >, Select ▼, or Select ▲ to highlight the photo you want to print.

Caution

Don't remove a card from the slot while you're printing or you may damage the card. Wait until printing is finished and the Card light shines green or turns off before removing the card.



Note

To rotate or crop the photo before printing, press the Enter button on the remote control. Rotate the image or zoom in on the desired portion of it, as needed (see page 83). The photo prints the way you see it on the screen.

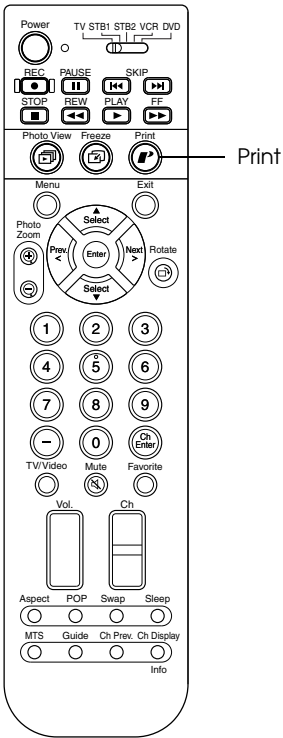

- 2 Press the Print button on the TV panel or remote control. You see the Print Settings screen:



- 3 To print one copy of the photo, press Enter.

To print multiple copies, press Prev. < or Next > until the number in the Copies box is correct. Then press Enter.

After a moment, printing starts.

During printing, the Printer light flashes. When printing is finished, the Printer light turns off.

- 4 To print additional photos, repeat these steps. You can send multiple photos for printing at one time, up to 15 photos.

To monitor your print job or to cancel it, see the next section.

If you see a printing error message, select Yes to check for the problem. Then follow the on-screen instructions to solve the problem and continue printing. For additional help, see page 115.

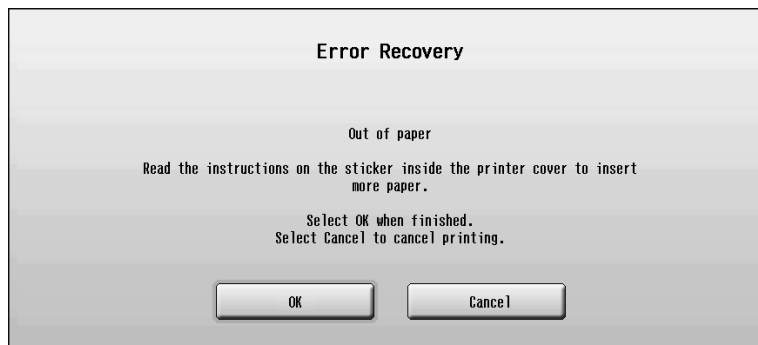

When you're finished printing, remove the borders from the edges of your photo by bending them back and forth and tearing them off.

Monitoring or Cancelling Your Print Jobs

Once you send a photo for printing, you can monitor its progress or cancel it.

- 1 Press the 4 button. (Or press Menu, press Select ▼ to highlight Print Monitor, and press Enter.) The Print Monitor menu opens.



- 2 To monitor your print jobs, press Enter to choose Select Print Job. You see the Print Monitor screen:



The status of each print job is listed below the photo.

Cancelling an Individual Print Job

- 1 Press Prev. <, Next >, Select ▼, or Select ▲ to highlight the job and press Enter. You see the Printing or Waiting screen:



- 2 Press Select ▲ to highlight Cancel and press Enter.

(If the print job has finished before you could cancel it, press Select ▼ to highlight Exit and press Enter.)

- 3 Select Yes on the next screen. Your print job is cancelled.

Cancelling All Print Jobs

- 1 Press the 4 button. (Or press Menu, press Select ▼ to highlight Print Monitor, and press Enter.)
- 2 Press Select ▼ to highlight Cancel All Print Jobs and press Enter.
- 3 Select Yes on the next screen and press Enter. Your print jobs are cancelled.

Saving Photos to CD

Before you save photos on a CD, make sure you've connected the external CD-R/RW drive that came with your TV (see page 15) and turned on the drive.

You cannot write photos to a CD-R/RW disc that was previously written to by a computer. You can view and print photos from these discs, but you cannot write new photos to them using your TV. This is because your TV and computer use different methods for writing files. When you want to write photos to a CD-R/RW, use only a new, blank disc.

Make sure that your disc can be written to at 4X speed. Some high-speed discs don't support 4X writing, so check your disc specifications before inserting it into the drive.

Note

You can't write photos to a CD-R/RW while viewing photos on a CD-R/RW.

Follow the instructions in "Inserting a Photo Card" on page 78 to insert your digital photo card and open the photo viewer. Then follow the steps in the next section to insert a CD-R/RW in the drive and write the photos to it.

Inserting a CD-R/RW

- 1 Press the eject button on the drive to open the tray.
- 2 Place a new, blank CD-R/RW disc on the tray with the label side facing up. Make sure the disc lays flat in the tray.

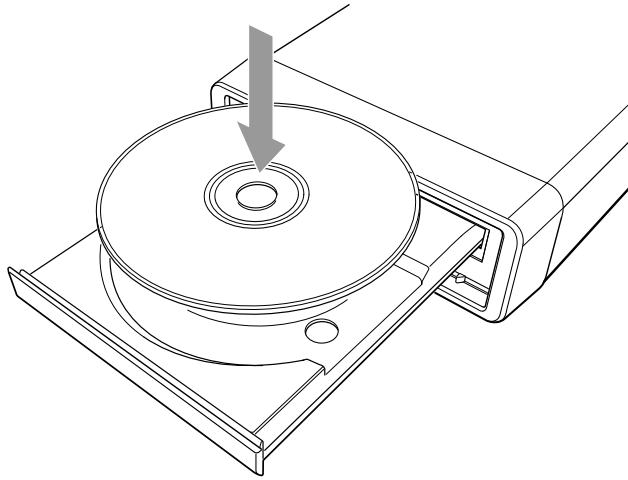

- 3 Press the eject button again to close the tray.

Writing All Photos to a CD-R/RW

- 1 Press the 3 button. (Or press Menu, press Select ▼ to highlight CD-R/RW Writer, and press Enter.) The CD-R/RW Writer menu opens.



- 2 To write all of the photos on your digital photo card to the CD, press Enter to select Write to CD-R/RW.
- 3 You see a confirmation message. Select Yes and press Enter. (To cancel, select NO and press Enter.)

Caution

Always use the eject button to open and close the tray. Pushing in the tray may damage the drive and your disc.

Caution

Don't remove a card from the slot while you're writing to CD-R/RW or you may damage the card or your CD-R/RW drive. Wait until writing is finished and the Card light shines green (or is off) before removing the card.

Note

The photo viewer cannot display, enlarge, or print TIF images. You see only the  icon on the viewer screens for TIF images. You can write TIF images to a CD-R/RW and view them on your computer, however.

Caution

Don't eject a disc, remove a digital photo card, or disconnect or turn off the CD-R/RW drive while you're writing to a disc. You may damage your disc, card, or drive.

- 4 You see a writing confirmation message while your photos are written to the CD and the drive light flashes. When it's finished, the CD tray opens and you see a completion message. Press Enter.

Selecting Photos for Writing to CD-R/RW

- 1 To select only some of your photos for writing to CD, press the 3 button to open the CD-R/RW Writer menu.
- 2 Do one of the following:
 - To write most of the photos to a CD, press Select ▼ to highlight Select all and press Enter. All your photos appear with checkboxes, indicating they are selected. Deselect any photos you don't want to write to the CD.
 - To write only a few photos to a CD, press Select ▼ to highlight Cancel all and press Enter. Select only the photos you want to write to the CD.



- 3 When you're ready to write the photos to the CD, press the 3 button, then press Enter to select Write to CD-R/RW.
- 4 You see a confirmation message. Select Yes and press Enter. (To cancel, select NO and press Enter.)
- 5 You see a confirmation message while your photos are written to the CD. When it's finished, the CD tray opens and you see a completion message. Press Enter.

Viewing Photos Written to a CD-R/RW

- 1 Press the eject button to re-insert the CD.
- 2 Press the 1 button to open the Photo Source menu.
- 3 Press Select ▼ to highlight CD-R/RW and press Enter. Your photo folders appear.
- 4 Press Prev. <, Next >, Select ▼, or Select ▲ to select a folder and press Enter. You see your photos. To view photos in another folder, press Exit; then repeat this step.

Caring For the TV

To keep your TV clean and operating correctly, or to move it to another location, follow the steps in these sections:

- “Cleaning the TV” below
- “Cleaning the Air Filter” below
- “Replacing the TV Projection Lamp” on page 97
- “Replacing the Printer Ink Cassette” on page 101
- “Moving or Transporting the TV” on page 107

Cleaning the TV

Remove dust from the screen using only a soft, lint-free cloth, such as a lens-cleaning cloth or a flannel or microfiber cloth. If necessary, moisten the cloth with water and diluted mild detergent.

Don't press too hard as you clean the screen.

Clean the rest of the TV in the same way. Keep the panel covers closed as you clean and avoid dampening the connectors on the back.

Cleaning the Air Filter

You need to clean the TV's air filter periodically—about once a month—to make sure the TV doesn't overheat due to insufficient ventilation.

- 1 Pull out and remove the vent cover on the left side of the TV.

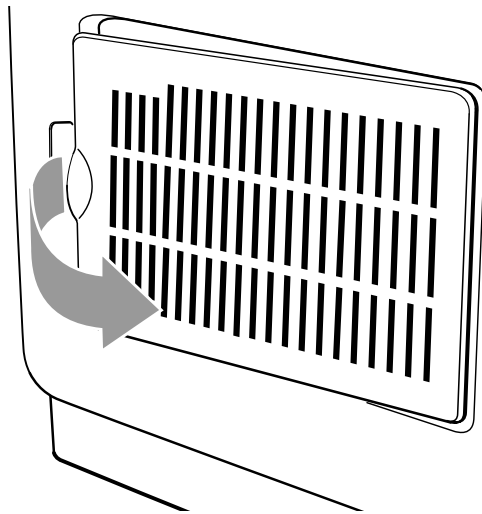

Caution

Don't use strong or abrasive cleaning solutions to clean the screen. Never use alcohol, benzene, wax, window cleaner, scouring powder, or other cleaners.

- 2** Use a small, hand-held vacuum to remove dust from both sides of the vent cover.

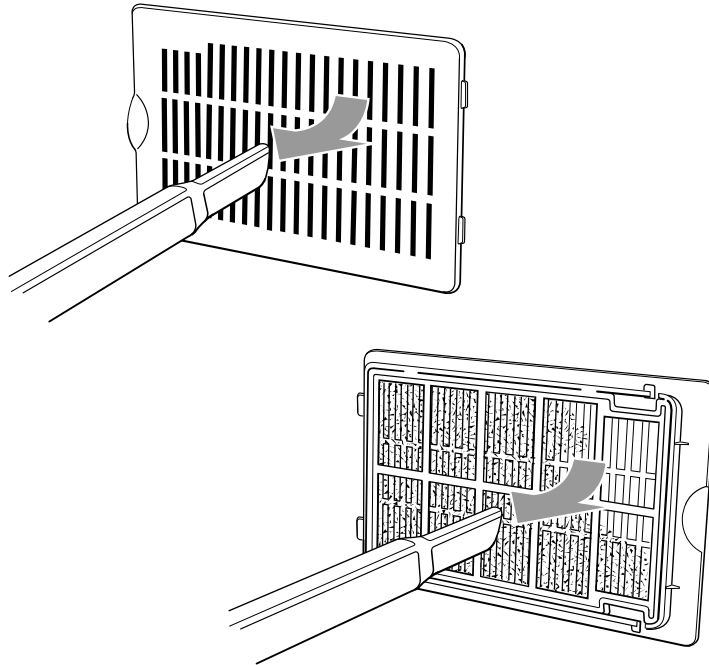

- 3** To replace the vent cover, insert the tabs on the back into the right side of the vent opening. Then press in the left side of the vent cover.

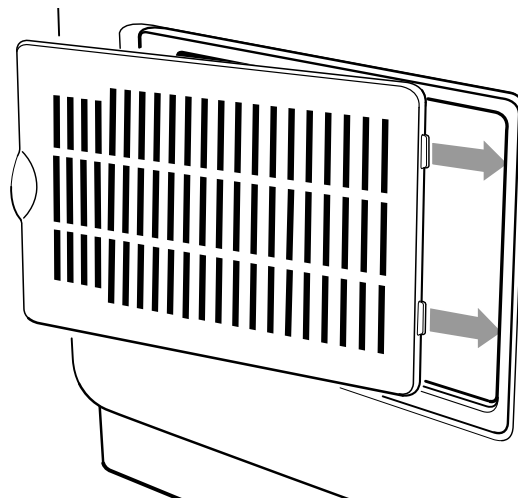

Replacing the TV Projection Lamp

The projection lamp in your TV is designed to last approximately 10,000 hours. Lamp life will vary depending on the mode selected, environmental conditions, and usage.

When it is time to replace the lamp, the TV displays a message on the screen.

The Lamp and Power lights on the front of the TV also indicate the status of the lamp.

You can purchase replacement lamp number V13H010R02 from your dealer or Epson. Call (800) 873-7766 or visit the Epson Store at www.epsonstore.com (U.S. sales only). In Canada, please call (800) 463-7766 for dealer referral.

Don't replace the lamp unless you see a screen message or the Lamp and Power lights indicate lamp replacement, as described in the table below:

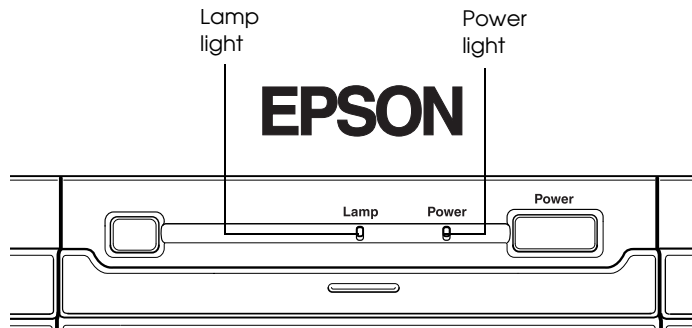

Caution

If your picture quality is not what it should be, try the other solutions described in "Picture Problems" on page 112 to correct it. If none of them work, you may need to replace the lamp. However, contact Epson (see page 121) to see if lamp replacement would help before replacing the lamp unnecessarily.

Turn off the TV when not in use. Continuous 24-hour-a-day use may reduce its overall life.

Lamp light status	Power light status	Action
Orange flashing	Any state	Lamp replacement warning The projection lamp is almost burned out. You may also see a message on the screen. Obtain a replacement lamp, then follow the steps on page 98 to replace it.
Red	Red	Lamp error The projection lamp has burned out or has another problem. Obtain a replacement lamp, then follow the steps on page 98 to replace it.
Red flashing	Red	Lamp cooling or open cover error Make sure the lamp cover is closed completely. See the steps for accessing the cover on page 98. If the cover is closed, the lamp may not have cooled completely before the cover was opened. Wait a few minutes until the fan stops running, then unplug the TV, plug it back in, and press the Power button to turn on the TV. If the error persists, contact Epson as described on page 121.

Lamp Replacement Precautions

- Never touch the projection lamp immediately after turning off the TV or you could be burned. Wait at least 30 minutes after turning off the TV to let the lamp cool down completely.
- If the lamp has broken, handle the shards carefully to avoid injury.
- The used lamp contains mercury. Please consult your state and local regulations regarding disposal or recycling. Do not put the lamp in the trash.
- Install the new lamp securely to avoid an electrical short or other damage. Insert the lamp as described below, pushing it all the way into its slot. Tighten the screws to lock the lamp securely into place or the lamp will not come on.
- Do not touch the glass on the lamp with your bare hands. This can shorten the lamp life and obscure the projected image. Use a cloth or glove to handle the new lamp.
- Do not drop the replacement lamp or bump it against any surface; the lamp could be permanently damaged.

Removing and Installing the Lamp

- 1 Turn off the TV, unplug it from the electrical outlet, and let it cool down for at least 30 minutes.
- 2 Make sure you have a replacement lamp (part number: V13H010R02).
- 3 Grasp the right speaker cover on the bottom and side, pull it off, and set it aside.

WARNING

The lamp is very hot. You must let it cool down for at least 30 minutes before you touch it or you could be burned.

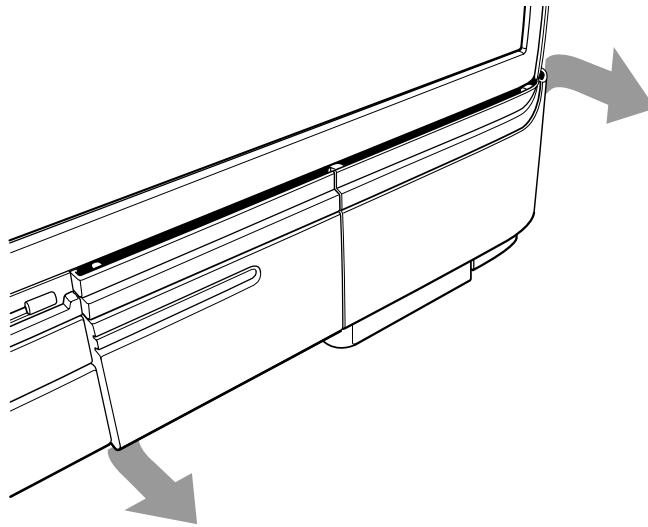

- 4 On the front of the TV, push in the latch on the lamp cover, then pull off the cover and set it aside.

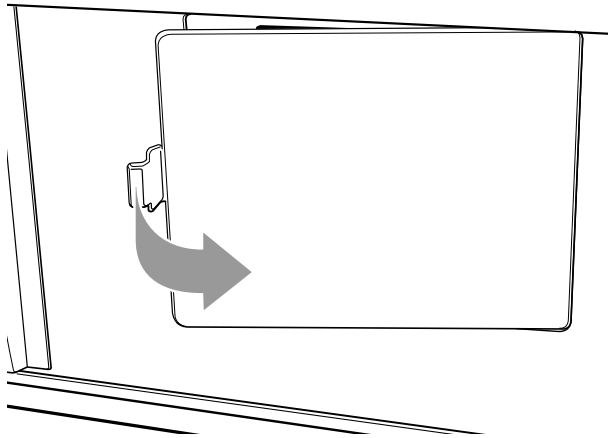

- 5 Use the screwdriver that came with the replacement lamp to loosen the two screws in the corners of the lamp housing. (You can't remove the screws.)

Caution
Don't loosen the two screws securing the handle to the lamp housing.

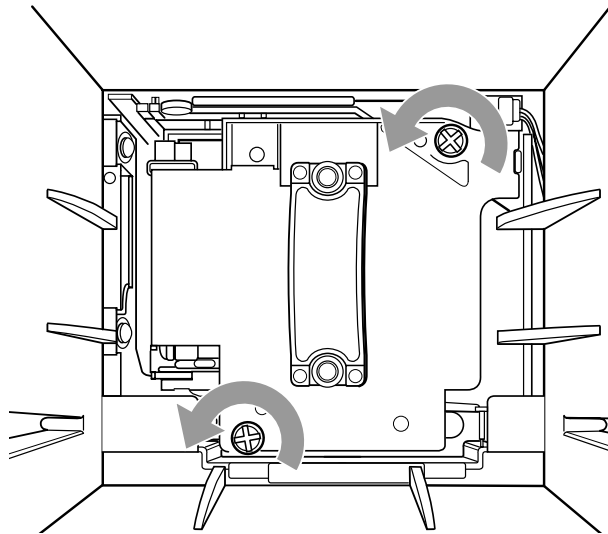

- 6 Grasp the handle on the lamp and pull it out of the TV. Set it aside carefully.

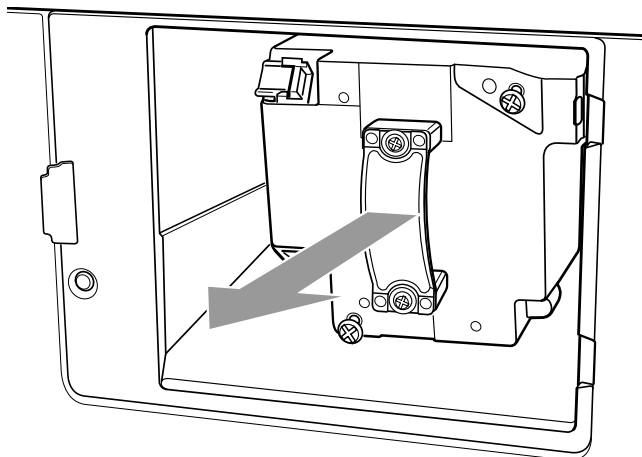

- 7** Position the new lamp as shown below. Then slide it carefully into the lamp slot until it stops.

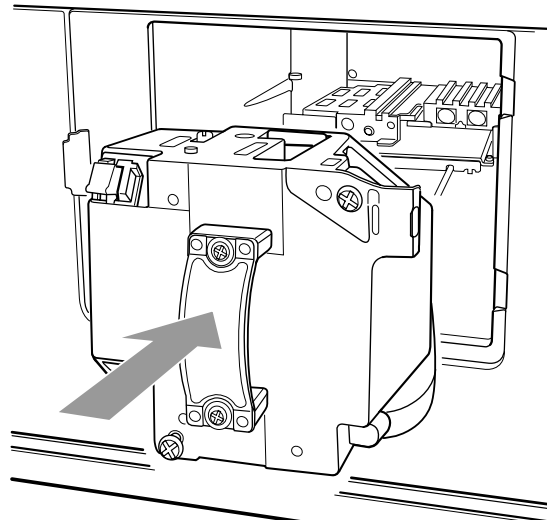

- 8** Tighten the screws in the corners of the lamp housing.
- 9** Insert the tabs on the lamp cover into the right side of the opening. Then push in the left side to close the cover.

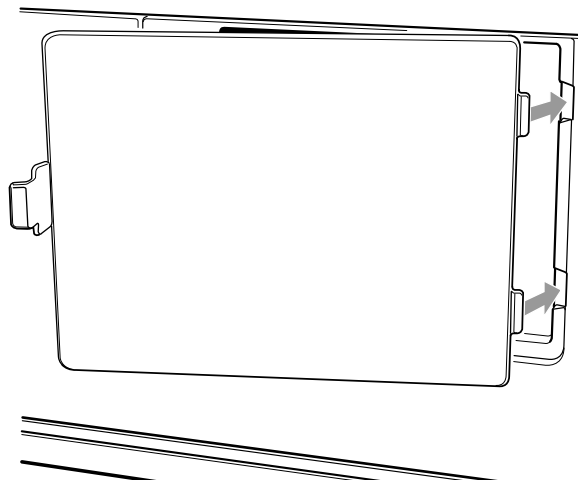

- 10 Align the speaker cover over the TV, making sure it fits into the holes. Push in on all sides of the cover.

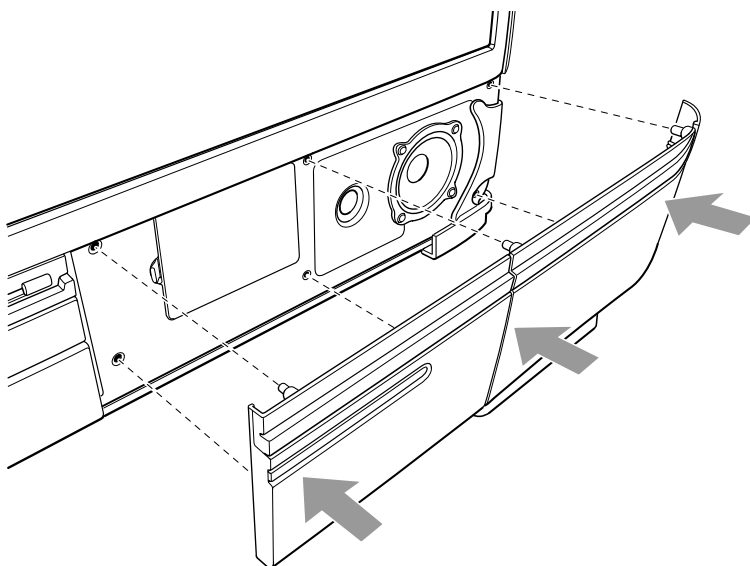

- 11 Plug in the TV and press the Power button to turn it on.

If the Lamp and Power lights come on or flash red, you may not have installed the lamp correctly or completely closed the lamp cover. Check the cover and lamp installation, making sure you followed all the steps above.

Replacing the Printer Ink Cassette

Make sure you have a new ink cassette before you begin. You can purchase Photo Printing Packet number V13H151010 containing 50 sheets of paper and an ink cassette from your dealer or Epson. Call (800) 873-7766 or visit the Epson Store at www.epsonstore.com (U.S. sales only). In Canada, please call (800) 463-7766 for dealer referral.

Sliding Out the Printer

- 1 Press and release the printer cover latch to open the cover.

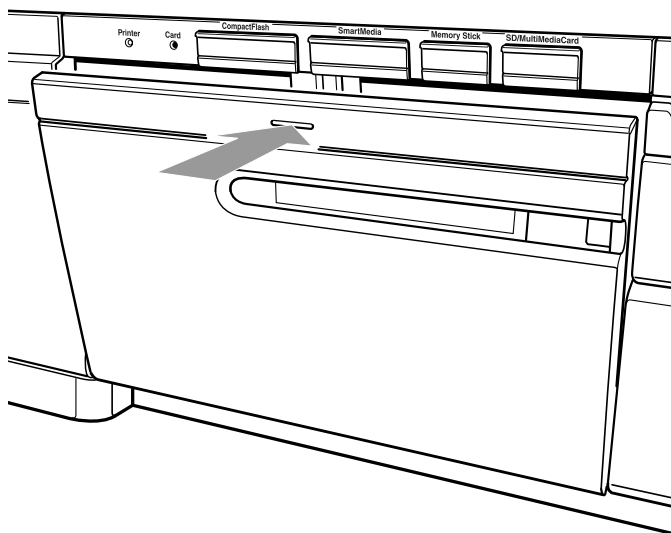

- 2 Flip down the printer lock cover.

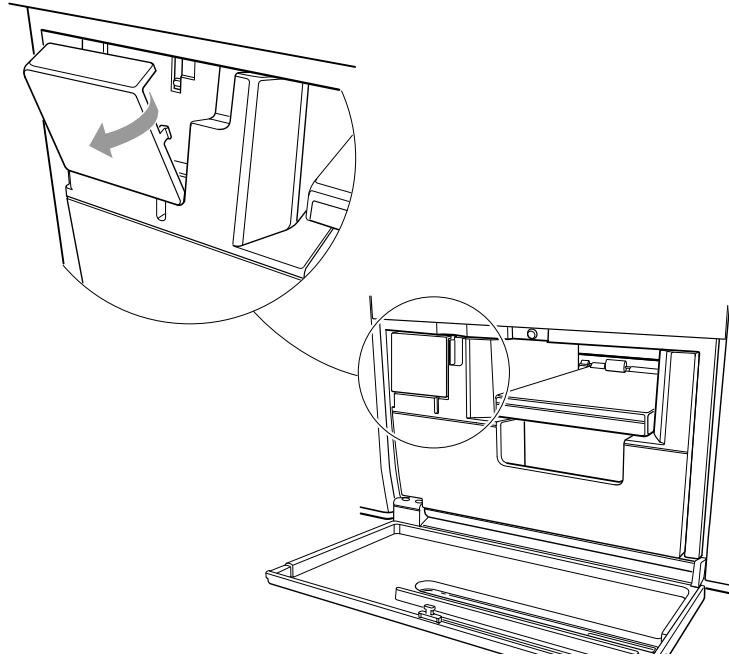

- 3 Turn the printer lock counterclockwise to loosen it. It spins freely when it is unlocked.

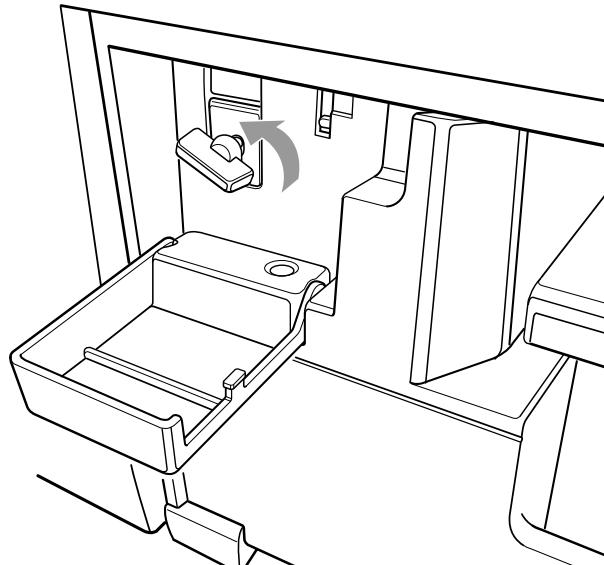

- 4 Grasp the printer handle and pull the printer out as far as it goes.

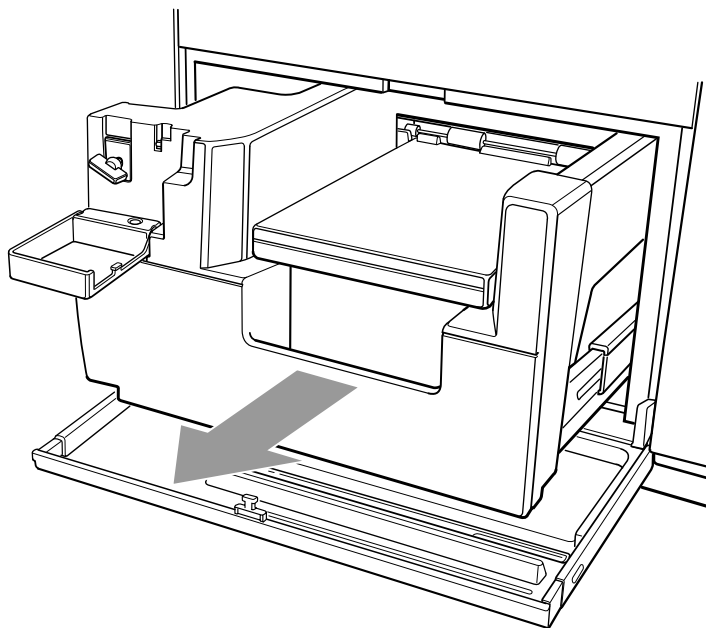

Removing and Replacing the Ink Cassette

- 1 Pull open the ink cover on the side of the printer.

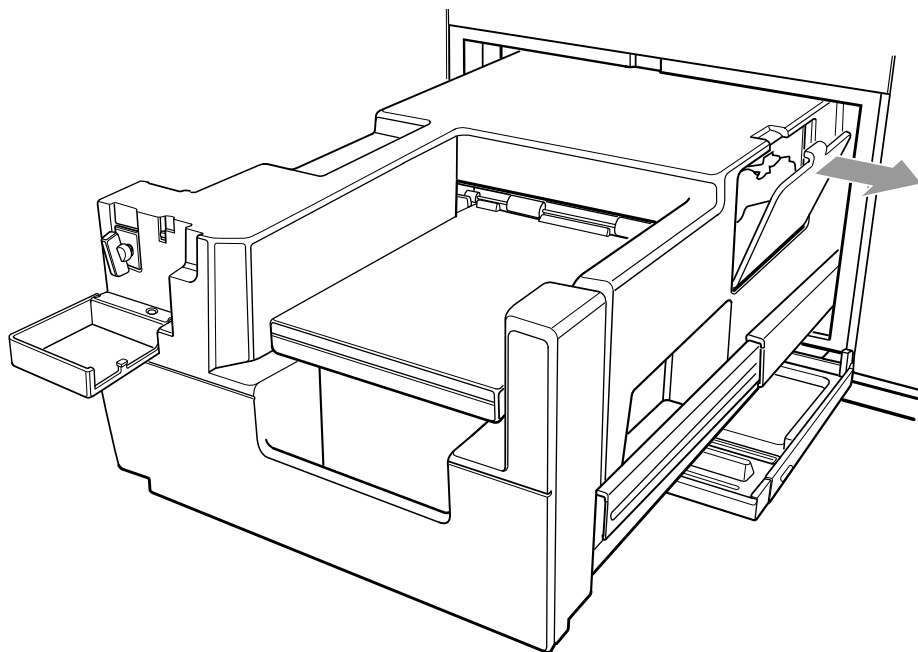

- 2** Lift up the ink cassette latch, then carefully pull out the cassette.

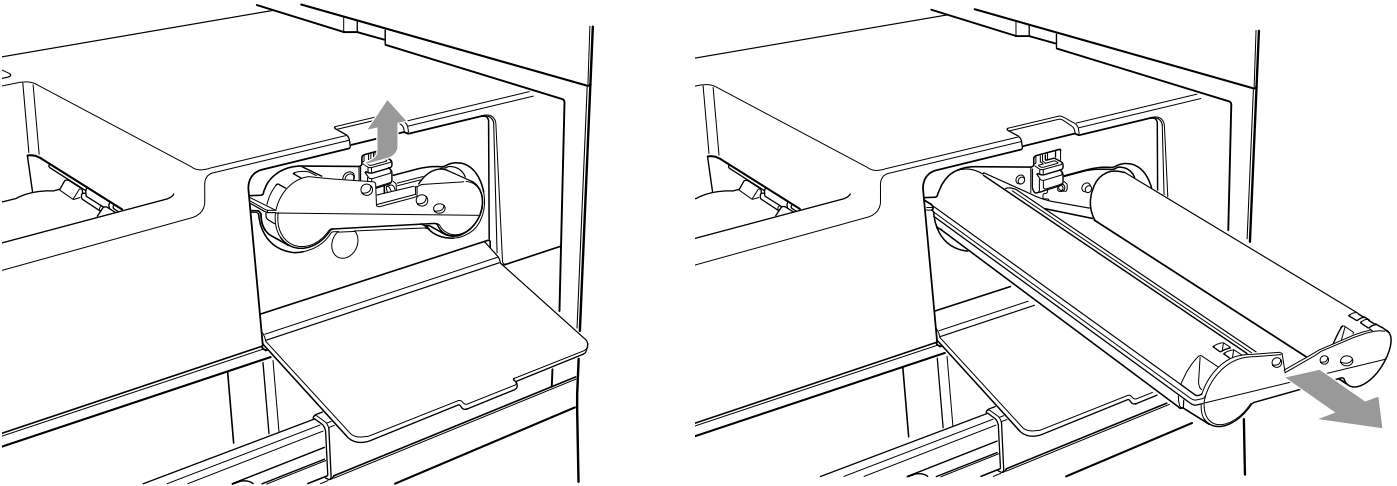

- 3** Remove the new cassette from its package. Then remove the red paper strip from the end.

Caution

If the ink ribbon catches in the opening, carefully adjust it so it doesn't tear.

- 4** Position the cassette as shown below. Then carefully align the cassette and its ribbon with the cassette slot.

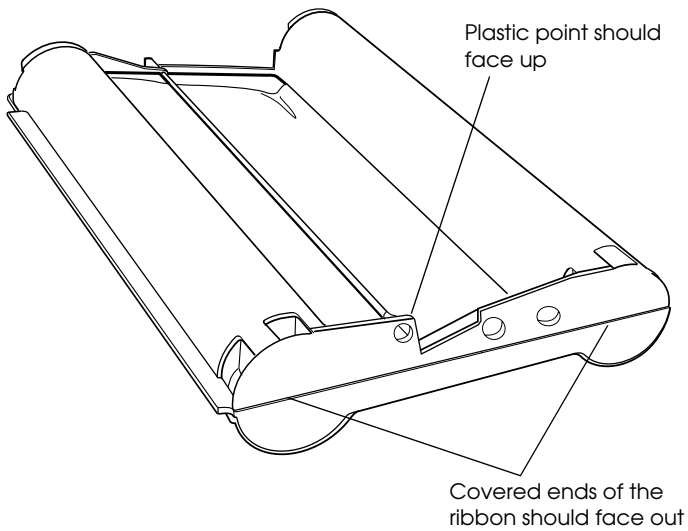

- 5 Once it is aligned, gently push the cassette into the slot until it clicks into place beneath the latch.

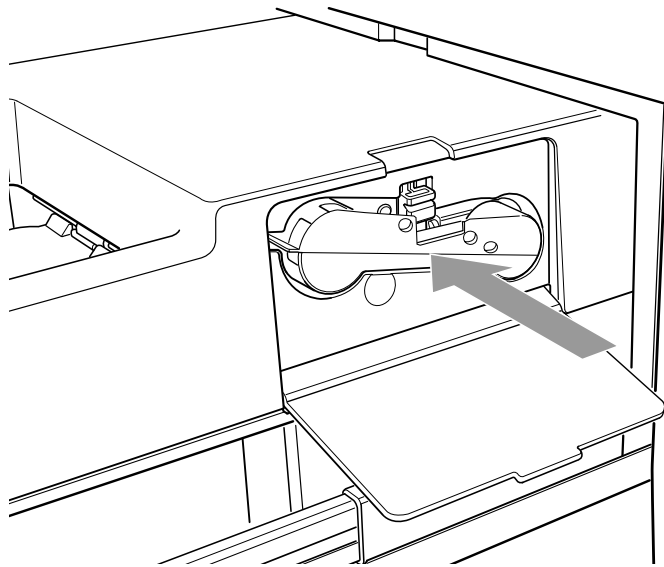

Caution

You must align the cassette and its ribbon with the slot or you will damage it when you slide it in.

- 6 Flip up the ink cover and push it closed.

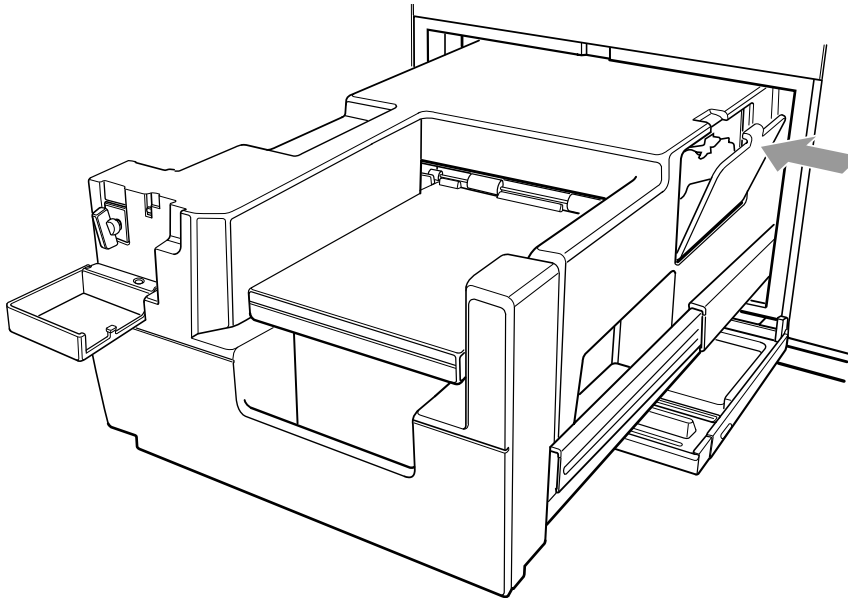

Sliding the Printer Back In

- 1** Slide in the printer until it stops. If the printer catches on the opened printer door beneath it, gently hold the cover down and out of the way as you slide the printer in.
- 2** Push in on the printer lock as you turn it clockwise to tighten it. If it doesn't tighten, push the printer in further and try again.

Caution

Make sure to lock the printer securely and close the lock cover completely or the printer won't print.

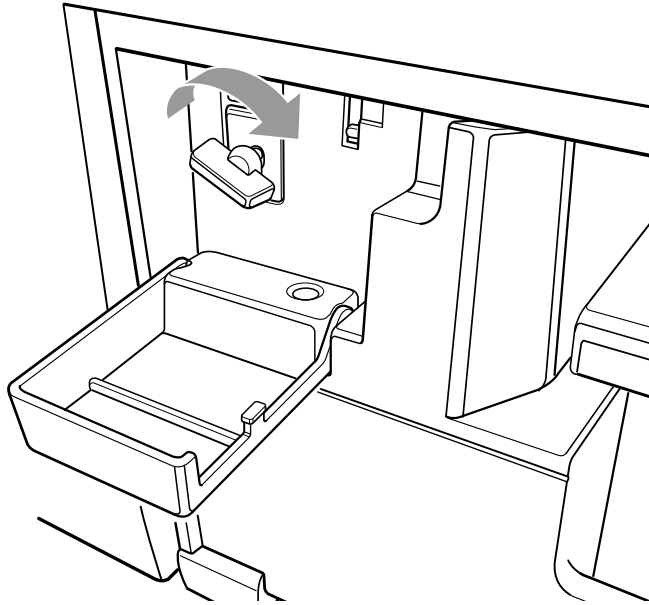

- 3** Flip up the lock cover.

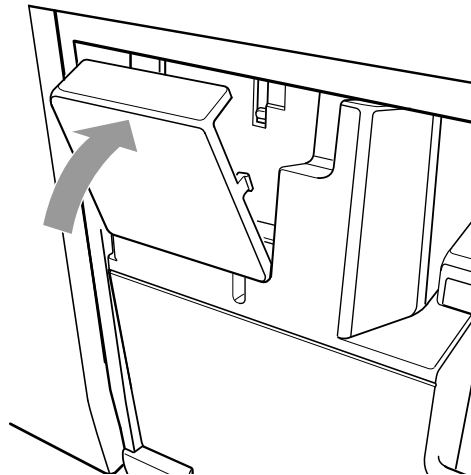

- 4** Close the printer cover.

If you see any error messages when you print, you may need to reinstall the ink cassette. Carefully follow the steps in this section to reinstall it.

Moving or Transporting the TV

When moving the TV, have two people grasp the TV as shown below. Lift the TV using the handles on the back and the top of the TV frame in the front.

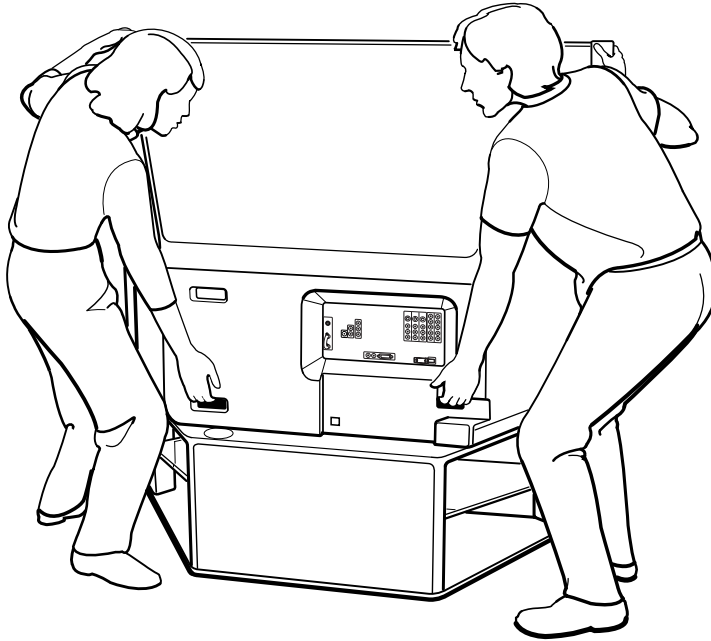

When shipping the TV or transporting it for a long distance, pack it in its original box using the original packing materials.

WARNING

The TV is very heavy. Two people are required to lift or move the TV to avoid injury.

Never move the TV and its stand or other support together or the TV may fall and cause injury or be damaged.

Be careful not to drop the TV during transport; it may cause injury or the TV may be irreparably damaged.

Solving Problems

If you have a problem with the TV, read any error messages on the screen and check the lights on the front panel. Then follow the suggested solutions in these sections:

- “Responding to Screen Error Messages” below
- “Responding to TV Panel Light Indicators” on page 110
- “Basic Operation Problems” on page 112
- “Picture Problems” on page 112
- “Sound Problems” on page 113
- “TV Reception or Operation Problems” on page 114
- “Remote Control Problems” on page 114
- “Problems Viewing Photos from Cards or Discs” on page 115
- “Printing Problems” on page 115
- “Problems Saving Photos to a CD-R/RW” on page 121
- “Where to Get Help” on page 121

Responding to Screen Error Messages

Message	Action
Replace the Lamp	The projection lamp is almost burned out. Order replacement lamp number V13H010R02, then follow the steps on page 97 to replace it.
The TV is overheating.	The TV is overheating and the lamp has turned off automatically. Turn off the TV and let it cool for a few minutes. Make sure there is plenty of space around the TV and that none of the ventilation slots are obstructed. If necessary, clean the TV's air filter, as described on page 95. Then turn the TV back on. If it continues to overheat, contact Epson as described on page 121.

Responding to TV Panel Light Indicators

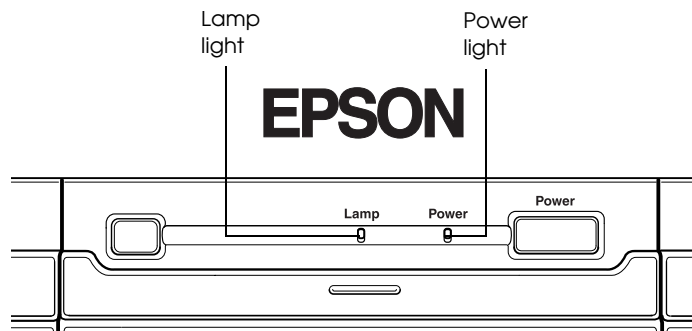

Lamp and Power light status

Lamp light	Power light	Status
Off	Green	Ready The TV is operating normally.
Off	Green flashing	Warm-up mode After a moment, your image will appear.
Off	Orange flashing	Cool-down mode Wait until the Power light stops flashing. When it lights orange without flashing, you can turn the TV back on or unplug it.
Off	Orange	Standby mode To turn the TV back on, press the Power button. If you need to disconnect the power, you can unplug the TV.
Orange flashing	Any state	Lamp replacement warning The projection lamp is almost burned out. You may also see a message on the screen. Obtain a replacement lamp, then follow the steps on page 97 to replace it.
Red	Red	Lamp error The projection lamp has burned out or has another problem. Obtain a replacement lamp, then follow the steps on page 97 to replace it.
Red flashing	Red	Lamp cooling or open cover error Make sure the lamp cover is closed completely. If the cover is closed, the lamp may not have cooled completely before the cover was opened. Wait a few minutes until the fan stops running, then unplug the TV, plug it back in, and press the Power button to turn on the TV. If the error persists, contact Epson as described on page 121.
Orange	Red	High temperature warning The TV is overheating and the lamp is turned off automatically. Turn off the TV and let it cool for a few minutes. Make sure there is plenty of space around the TV and that none of the ventilation slots are obstructed. Then turn the TV back on. If it continues to overheat, contact Epson as described on page 121.

Lamp and Power light status

Lamp light	Power light	Status
Off	Red	Internal error The TV has an internal problem. Press the Power button to turn off the TV and then unplug it. Contact Epson as described on page 121.
Orange flashing	Red	Fan or temperature sensor error The cooling fan or temperature sensor has a problem. Press the Power button to turn off the TV and then unplug it. Contact Epson as described on page 121.

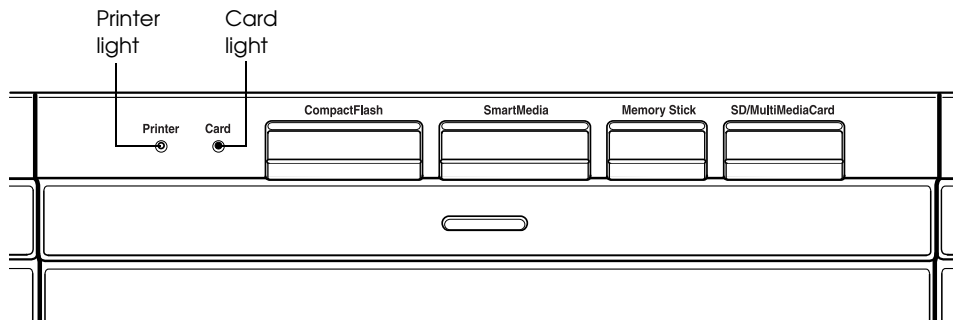

Printer light status

Printer light	Status
Off	The printer is in standby mode and is ready to print a photo.
Green flashing	The printer is currently printing a photo or an image frozen on using the Freeze for printing feature. Don't remove a photo card or CD-R/RW from the slot or drive while the Card light is orange or flashing orange and the Printer light is flashing green or you may damage the card, disc, or drive.
Red	The printer has encountered an error and displays an error message on the screen. Follow the instructions in the screen message to solve the problem. For details on printing, see page 86.

Card light status

Card light	Status
Orange	The TV is initializing the photo viewing system. When it's finished, the Card light turns off. Wait to insert another card or press the Photo View button until the Card light turns off; the TV won't be able to recognize the new card or respond to the button command.
Orange flashing	The TV is reading photos from a digital photo card, accessing the CD-R/RW, or printing photos. Don't remove the photo card or CD while the light is orange or flashing orange or you may damage the card, disc, or drive.
Green	The TV is displaying photos from a digital photo card or CD-R/RW. If necessary, you can remove the card or disc safely.
Off	If a card is inserted in a slot, the photo viewer is finished accessing it. You can safely remove the card.

Basic Operation Problems

Problem	Solution
The power won't come on.	<p>Make sure your electrical outlet is working and isn't controlled by a switch or timer.</p> <p>Check that the power cord is connected securely.</p> <p>If the Power light is flashing orange, the TV is cooling down. When it stops flashing and lights orange, you can unplug it or press the Power button to turn it on.</p> <p>If the Power light is flashing green, the TV is warming up. When it stops flashing and lights green, the TV is ready.</p> <p>If the Power light is red, you may have a problem with the TV, depending on the state of the Lamp light. See "Responding to TV Panel Light Indicators" on page 110.</p>
The buttons on the TV panel don't work.	When the TV is warming up or cooling down (the Power light is flashing), you can't use the buttons. When the Power light stays lit green or orange, the buttons are operable.
The TV's fan keeps running when the TV is turned off.	The TV cools itself down using internal power even after you turn it off.
You forgot the password you set up.	Follow the steps on page 53 to access the Lock menu, then enter the master password 0500. Continue following the steps to enter your password again. Make a note of the password you choose.

Picture Problems

Problem	Solution
You don't see a picture or hear any sound.	<p>If you see the "Signal is not supported" message on the screen, check the signal output by the equipment you have connected. If you connected to a computer, it may be outputting an incorrect refresh rate.</p> <p>If you see the No Signal message, check that your equipment is connected to the TV correctly and that you've put in a disc, tape, or other media, if necessary.</p> <p>If there are no messages on the TV screen, see if the TV is still warming up (the Power light is flashing green). If so, wait until the light stays lit green.</p> <p>Check the equipment you connected to make sure you selected the correct settings for sending images to the TV.</p> <p>If you locked an input source from use using the menus, you need to unlock it. Press the MENU button on the TV panel or remote control. Then follow the steps on page 59 to unlock the input source.</p>
You hear sound, but you don't see a picture or the picture doesn't look right.	<p>Make sure the cables are connected to the TV and your equipment correctly. See page 16 for instructions.</p> <p>Check the equipment you connected to make sure you selected the correct settings for sending images to the TV.</p>
The picture displays with stripes, ghosting, snow, or static.	Check your TV reception and connections. Weather conditions and interference from other nearby equipment may be affecting the picture quality. Turn off or relocate equipment such as hair dryers or microwave ovens, if possible.

Problem	Solution
The picture contains no color or incorrect colors.	<p>Select a different Color Mode as described on page 63.</p> <p>Check your TV reception and connections. Weather conditions and interference from other nearby equipment may be affecting the picture quality. Turn off or relocate equipment such as hair dryers or microwave ovens, if possible.</p> <p>Check the equipment you connected to make sure you selected the correct settings for sending images to the TV.</p> <p>If the color is uneven in all the corners of the image, your TV may have an internal problem. Contact Epson for more information.</p>
The picture is dark.	<p>Press the Menu button on the TV panel or remote control. Then follow the steps on page 63 to adjust the brightness and other picture settings.</p> <p>The TV's projection lamp may need to be replaced soon.</p>
The screen has some bright spots or dark spots.	The TV's LCD screen contains a 99.99% accurate dot display. However, some individual dots may appear bright or dark.
The picture is cut off.	<p>Press the Aspect button on the remote control to change the TV's aspect ratio, or the size and format of the display. Depending on the type of video you're viewing, the ratio may cause part of the image to be cut off.</p> <p>If you're zooming in on a DVD image, make sure the DVD player's aspect ratio is set to 16:9. Then set the TV's aspect ratio to FULL.</p>
A black frame appears around the picture.	Closed captioning is turned on. To turn it off, follow the instructions on page 75.

Sound Problems

Problem	Solution
You see a picture, but you don't hear any sound or the sound is flawed.	<p>Press the Mute button on the remote control. If you had muted the sound, it should return.</p> <p>If the sound wasn't muted, press the Volume up button on the TV panel or remote control to turn up the volume.</p> <p>If you're using headphones, the speakers are automatically turned off while the headphones are connected.</p> <p>Make sure the audio cables you connected for the input source you're trying to listen to are connected to the correct connectors. See page 16 for instructions.</p> <p>Press the Menu button on the TV panel or remote control. Check the Speaker setting on the Audio menu to make sure it isn't turned off. See page 68 for instructions.</p> <p>If you're using POP (picture-outside-picture), you only hear sound from the main picture source. To hear sound from the other source, press the Swap button on the remote control.</p> <p>Make sure the TV program, tape, disc, or other video medium actually includes sound.</p> <p>If you're watching a dual language program with multiplex audio or a supplementary soundtrack, the program may not be dual language or the TV may not be set to SAP mode. Press the MTS button on the remote control until you see SAP in the upper left corner of the screen. Also check that your antenna or cable connections are secure.</p>

TV Reception or Operation Problems

Problem	Solution
TV reception is poor.	<p>Check your antenna, cable, or digital or satellite receiver connections. See page 16 for details.</p> <p>Weather conditions and interference from other nearby equipment may be affecting the picture quality. Turn off or relocate equipment such as hair dryers or microwave ovens, if possible.</p>
The TV channels can't be changed or selected.	<p>When the TV is warming up or cooling down (the Power light is flashing), you can't use the buttons. When the Power light stays lit green or orange, the buttons are operable.</p> <p>You may have locked access to certain channels. Press the Menu button on the TV panel or remote control. Check the Channel Lock settings on the Lock menu as described on page 59.</p> <p>You may have marked the channel to be skipped. Press the Menu button on the TV panel or remote control. Check the Manual Program settings on the Channel menu as described on page 49.</p> <p>If your cable system added channels and you can't receive them, you need to run the Auto Program utility to add them to your TV's list of receivable channels. Press the Menu button on the TV panel or remote control. Select the Auto Program setting on the Channel menu as described on page 47.</p>
You can't receive a digital broadcast.	You must connect the TV to a digital TV receiver to receive digital broadcasts.

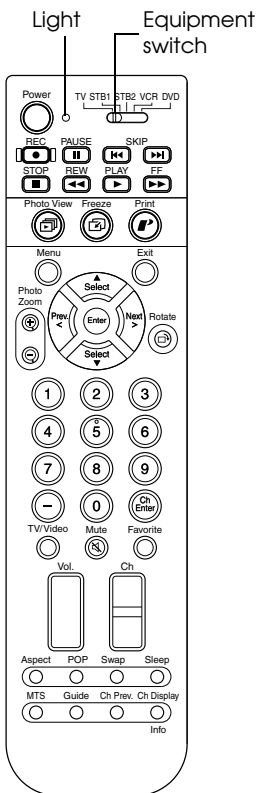

Remote Control Problems

Problem	Solution
The remote control doesn't work.	<p>If you have problems with the remote control, press any button on the remote to check if the light on the top comes on.</p> <p>If the light comes on, move closer to the TV when you use the remote control and aim it at a more direct angle. Make sure the room lighting is not too bright and not shining directly on the remote control or the TV receiver window. Also clean the transmitter area on the top of the remote and the receiver window on the TV to see if that helps.</p> <p>If the light doesn't come on, make sure the batteries are inserted correctly and are working. If necessary, replace the batteries.</p> <p>Make sure the equipment switch at the top of the remote control is set to the device you're trying to control.</p> <p>If you still have problems with the remote control, try the other suggestions on page 34.</p>

Problems Viewing Photos from Cards or Discs

Problem	Solution
You insert a card or CD, but you don't see your photos in the photo viewer screen.	<p>Make sure your card or disc actually contains photos and that the files aren't protected from viewing. Also make sure your whole photo card isn't protected from viewing. Your card should be formatted for multi-session packet writing and your files contained in a DCF compatible folder structure. See page 78 and page 80 for details.</p> <p>Your photos may not be in the correct format. They should be JPEG (not progressive JPEG) files with resolutions between 120 x 120 to 4600 x 4600 pixels. If your files are in this format and resolution range, look at them on a computer to see if you can see them there. If you can't, they are probably corrupted.</p>
Your photos don't look right when you view them in the photo viewer.	<p>Make sure your photos are in JPEG (not progressive JPEG) format and are between 120 x 120 and 4600 x 4600 pixel resolution.</p> <p>Check the TV's Color Mode, Brightness, and other picture quality settings (see page 63).</p>

Printing Problems

Check the icon on the screen while printing. If you see a message about checking for errors, select **Yes** and follow the on-screen instructions to correct the problem.



Icon	Problem and solution
	The printer has been pulled out of the TV. Make sure it is securely pushed back in and locked, as described on page 106.
	The printer's lock cover is not closed. Flip up the lock cover to close it (see page 106).
	The printer is out of paper or paper is jammed. See page 86 to load paper or page 117 to clear a paper jam.
	The printer is out of ink or no ink cassette is installed. See page 103 to replace the ink cassette.
	Unsupported file format or communication error. If you pulled out the printer during printing, push it back in as described on page 106. If you are printing an image from a CD or picture card, make sure the image is 3MB or smaller in size and meets the requirements on page 77 (for cards) or page 80 (for CDs).
	Hardware problem. If you see an error code on the screen, write down the code number. Contact Epson as described on page 121.
	Printing is in progress.

If you don't see an error icon, check here for more printing solutions:

Problem	Solution
You see an error message on the screen.	The printer may be out of paper or ink. Follow the on-screen instructions or the instructions on the sticker inside the printer door to replace paper or ink. If the on-screen message contains an error code, write down the code number and contact Epson as described on page 121.
You just replaced the ink cassette, but the printer is not working.	Make sure the printer is locked and the lock cover is closed, as described on page 106, or the printer won't print.
Nothing is printed.	If you removed a digital photo card or CD that contained the image you were printing, the TV cancels printing automatically. Insert the card or disc and print again. For detailed steps, see page 86. You may have set up too many photos to print at one time. You can send up to 15 photos or up to 3 captured images for printing at one time. Each photo or image must be 3MB or smaller.
A blank page prints.	Your ink cassette may need replacement. Obtain a Photo Printing Packet and replace the ink cassette as described on page 101.
The printed colors are incorrect, smudged, faded, or streaked.	Make sure you loaded the paper with the shiny side up. See page 86 for instructions. Your ink cassette may need replacement. Obtain a Photo Printing Packet and replace the ink cassette as described on page 101. Make sure your photo or image is 3MB or smaller in size. Printed colors can never exactly match the screen colors.
Paper is jammed in the printer.	If paper jams in the printer at the front, gently pull the paper out and try printing again. If paper is still jammed in the printer, you may need to clear the jam from the back of the printer. Follow the steps beginning on page 117 to clear the jam.

Clearing a Paper Jam From the Back of the Printer

- 1 Press and release the printer cover latch to open the cover.

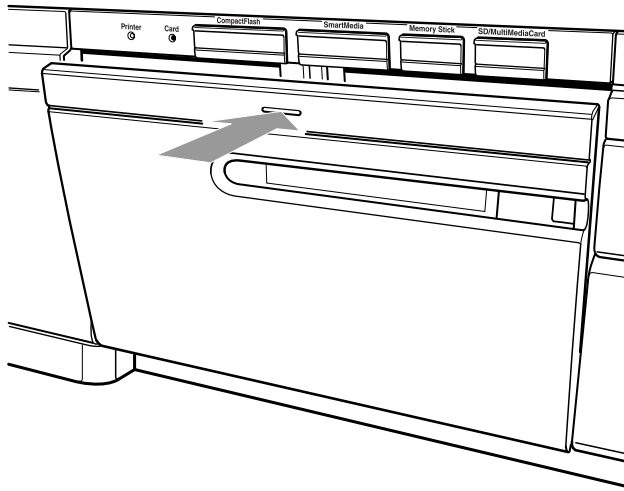

- 2 Flip down the printer lock cover.

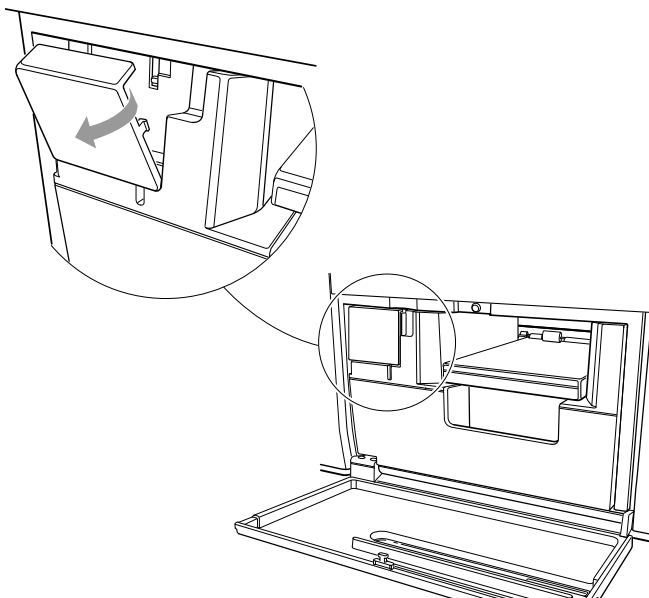

- 3 Turn the printer lock counterclockwise to loosen it. It spins freely when it is unlocked.

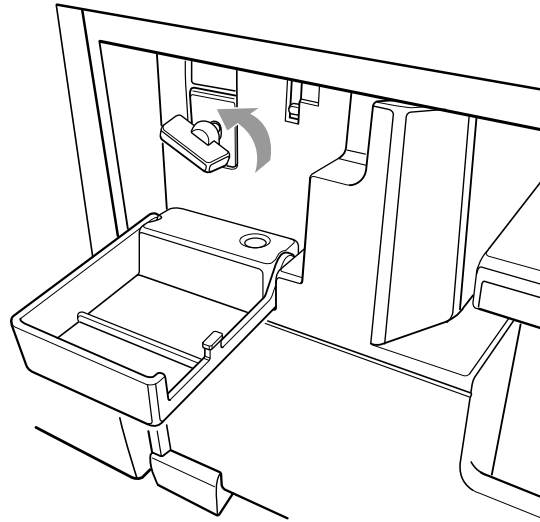

- 4 Grasp the printer handle and pull the printer out as far as it goes.

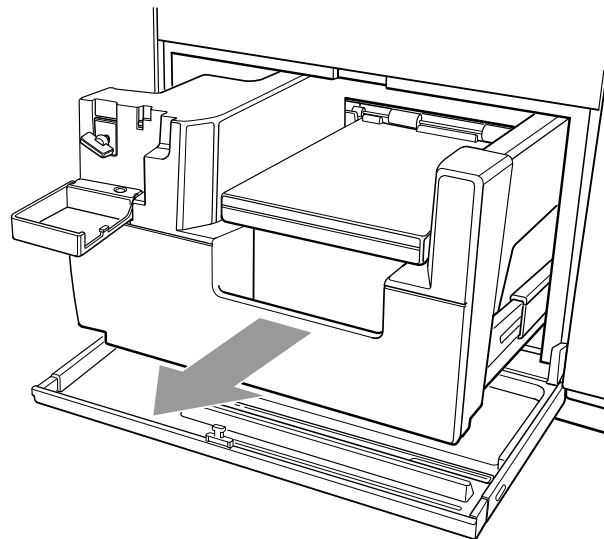

- 5** Use a Phillips-head screwdriver with a shaft at least 6 inches long to remove the 2 screws securing the printer on each side, as shown below.

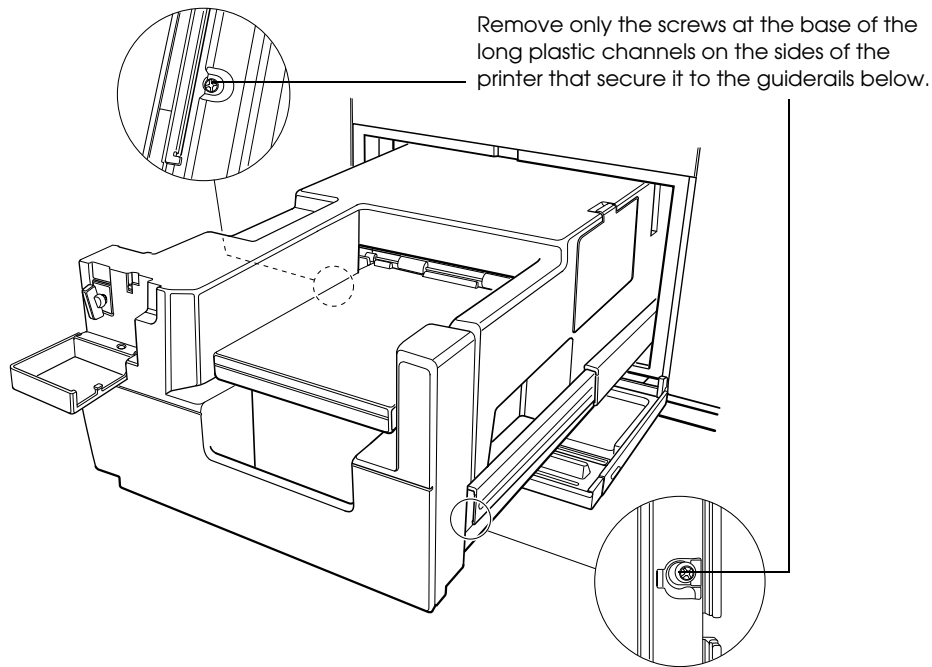

- 6** Lift up the front of the printer slightly and slide it forward off of its guiderails until you can access the back of the printer.
- 7** Open the back door of the printer and pull out any paper jammed inside.

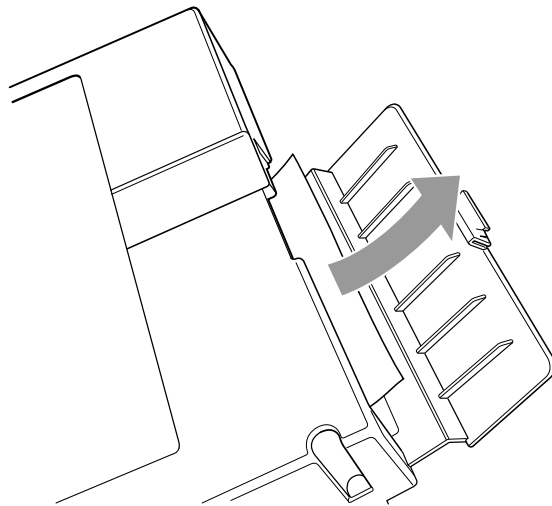

- 8** Close the back door.

- 9 Slide the printer back onto its guidrails and align the screws with the screw holes on each side.

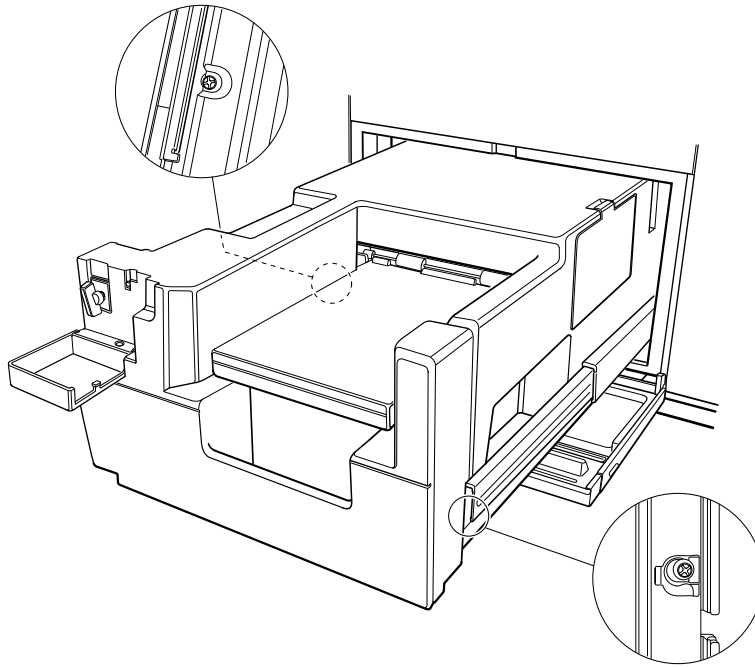

- 10 Tighten the screws securely, but don't over-tighten them.
- 11 Slide in the printer until it stops. If the printer catches on the opened printer door beneath it, gently hold the cover down and out of the way as you slide the printer in.
- 12 Push in on the printer lock as you turn it clockwise to tighten it. If it doesn't tighten, push the printer in further and try again.
- 13 Flip up the lock cover.

Caution

Make sure to lock the printer securely and close the lock cover completely or the printer won't print.

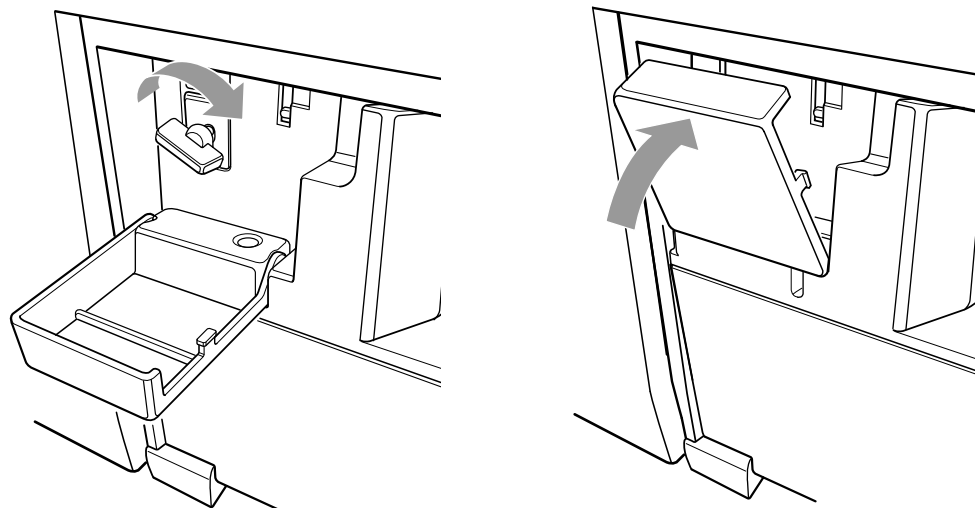

- 14 Close the printer cover.

Problems Saving Photos to a CD-R/RW

When the CD-R/RW Writer can't write your photo to a disc, or has another detectable problem, the TV displays an error message on the screen. Follow the on-screen instructions to solve the problem. If replacing the disc doesn't solve the problem, make sure you didn't damage the drive by removing a disc, photo card, or cable, or by turning off the power while writing to a disc.

If you previously wrote photos or other data to a CD-R/RW using a computer or other source, you cannot write photos to it with the TV. See page 93 for guidelines on writing photos to a CD-R/RW with your TV.

Where to Get Help

Epson provides technical assistance through the World Wide Web 24 hours a day. From the Internet, you can reach Epson's product support page at <http://support.epson.com>. After selecting your product, you can access troubleshooting information, download product documentation, and receive technical advice through e-mail.

Telephone Support Services

To use the Epson PrivateLineSM Support service, call (800) 637-7661 and enter the PIN on the Epson PrivateLine Support card included in your User's Guide kit. This is the fastest way of speaking to a live representative, and it's free. This service is available 6 AM to 6 PM, Pacific Time, Monday through Friday, for the duration of your warranty period.

You may also speak with a TV support specialist by dialing one of these numbers:

- U.S.: (562) 276-4394, 6 AM to 6 PM, Pacific Time, Monday through Friday
- Canada: (905) 709-3839, 6 AM to 6 PM, Pacific Time, Monday through Friday

Toll or long distance charges may apply.

Before you call, please have the following information ready:

- Product name (Epson Livingstation LS47P2 or LS57P2)
- Product serial number (located on the back left side of the TV; you may also have written it down on the *Quick Setup* sheet when you set up your TV)
- Description of the problem

You can purchase supplies and accessories from your dealer or from Epson. Call (800) 873-7766 or visit the Epson Store at www.epsonstore.com (U.S. sales only). In Canada, please call (800) 463-7766 for dealer referral.

Specifications

General

Projection system	3 LCD panel, 1 lens, rear projection
Television system	NTSC (American standard); 2 tuners
Channel coverage	VHF: 2 - 13 UHF: 14 - 69 CATV: 1 - 125

Note

Television specifications are listed here. Specifications for the HDTV tuner are listed in the tuner *User's Guide*.

Screen and Display

Screen size	LS47P2: 47 inches (119.4 cm) LS57P2: 57 inches (144.8 cm)
LCD panel	3 TFT panels with approximately 2.76 million dots total (1280 × 720 × 3)
Lamp	Short-arc, UHE (Ultra High Efficiency), 100 W; 10,000 hour life,* replaceable from front
Display format	720p
Aspect ratio	16:9

* Lamp life will vary depending on the mode selected, environmental conditions, and usage.

Mechanical

Cooling system	Quiet, dust-resistant, sealed housing
Height	LS47P2: 34.6 inches (878.8 mm) LS57P2: 39.5 inches (1003.3 mm)
Width	LS47P2: 45.7 inches (1160.8 mm) LS57P2: 54.4 inches (1381.8 mm)
Depth	LS47P2: 14.8 inches (375.9 mm) LS57P2: 16.3 inches (414.0 mm)
Weight	LS47P2: 106 lb (48.0 kg) LS57P2: 124 lb (56.2 kg)

Electrical

Power requirement	120 VAC, 2.3 A, 60 Hz
Power consumption	Operating: 280 W Standby: 1.1 W
Speaker Out	10 W × 2

Environmental

Operating temperature	41 to 95 °F (5 to 35 °C)
Storage temperature	14 to 140 °F (-10 to 60 °C)
Operating humidity	20 to 80%, non-condensing

Interfaces

Input interfaces

Video IN	4 total (3 in back, 1 in front), RCA-type; 1 V p-p, 75 ohms
S-Video IN	4 total (3 in back, 1 in front), S-type; Y: 1 V p-p, 75 ohms C: 0.286 V p-p, 75 ohms
Component Video IN	2 in back; 3 RCA-type; Y: 1 V p-p, 75 ohms, unbalanced, sync negative Pb, Pr: 0.7 V p-p, 75 ohms
DVI	1 in back, DVI-type; 3.3 V, TMDS, 50 V; DVI-HDTV, VGA, SVGA, XGA, SXGA
RF IN (Antenna)	2 in back, F-connector
Computer (RGB)	1 in front, D-sub-15-type; 0.7 V P-P, 75 ohms; VGA, SVGA, XGA, SXGA
Audio IN	8 total (6 in back, 2 in front), 2 RCA-type, except for 1 mini-jack (for PC) in front; 500mVrms, 47K ohms impedance

Output interfaces

Video OUT	1 in back, RCA-type; 1 V p-p, 75 ohms, unbalanced, sync negative
Audio OUT (Variable)	1 in back, 2 RCA-type; 1 V p-p, 600 ohms
Audio OUT (Fixed)	1 in back, 2 RCA-type; 1 V p-p, 600 ohms
RF OUT	1 in back, F-connector
Headphone	1 in front, stereo mini-jack; 5 V p-p (max)
Remote	1 in back, mini-jack for Xantech IR remote model 282 or 283

External interfaces

USB	1 in back, Type A (for external CD-R/RW drive only)
Serial	1 in back, D-sub 9-pin, RS-232C (for service use only)
Memory card	4 in front (1 each SD/MultiMediaCard, Memory Stick, CompactFlash, SmartMedia) JPEG, Exif (1.0 to 2.2), and DCF version 1.0 file system compliant

Printer

Type	Dye-sublimation thermal transfer printer
Resolution	300 dpi (equivalent to 4896 dpi on an ink jet printer)
Paper size	4 × 6 inches (10.2 × 15.2 cm)
Paper capacity	20 sheets
Print speed	110 seconds per sheet

Options

TV stand	For LS47P2: V12H003R03 For LS57P2: V12H003R02
Replacement lamp	V13H010R02
IR repeater	Recommend Xantech 282 or 283 M emitter
Printer pack	50 sheets, 4 × 6-size, and ink cassette: V13H151010

Safety

United States	UL60950 Third Edition
Canada	cUL (CSA C22.2 No.950 Third Edition)

EMI

United States	FCC Part 15B Class B
Canada	DOC ICES003 Class B

Notices

Epson America, Inc., Limited Warranty

What Is Covered: Epson America, Inc. (“Epson”) warrants to the original consumer purchaser that the Epson rear projection television product (including any accessories) enclosed with this limited warranty statement, if purchased new and delivered in the United States or Canada, conforms to the manufacturer’s specifications and will be free from defects in workmanship and materials for a period of two (2) years from the date of original purchase, except that the warranty period for the included lamp is 90 days from the date of original purchase. For warranty service, you must provide a sales receipt or bill of sale as proof of the date of purchase.

What Epson Will Do to Correct Problems: Should your Epson Product require service during the warranty period, you must contact Epson for service diagnostic and repair procedures. *For the television unit,* Epson will provide on site service to repair or replace the Product, at Epson’s option, without charge for parts or labor. On-site service may not be available in all areas or all instances. If on-site service is not available or cannot be accomplished, Epson has the option to perform repairs at an Epson authorized repair center, in which case Epson will arrange and pay for shipping to and from the repair location. In such case it may be necessary for Epson to remove the television unit and return it after the repair. *For included accessories (e.g., Printer, CD-RW drive, Remote Control, ATSC Tuner),* Epson will exchange the defective unit as needed without charge for parts or labor. With an exchange of a defective unit, Epson will ship a replacement unit to you, freight prepaid, to an address in the U.S or Canada. Shipments to other locations (Puerto Rico and U.S. Possessions) will be made freight collect. You are responsible for securely packaging the defective unit and returning it to Epson within five (5) working days of receipt of the replacement. Epson requires a debit or credit card number to secure the cost of the replacement unit in the event that you fail to return the defective one. In all cases where warranty service involves the replacement of the product or of a part, the item replaced becomes Epson property. The exchanged product or part may be new or previously repaired to the Epson standard of quality, or, at Epson’s option, may be another model of like kind and quality. Replacement products and parts assume the remaining warranty period of the product covered by this limited warranty.

What This Warranty Does Not Cover: This warranty covers only normal use of the Product in the United States and Canada. 24-hour-per-day use of this product causes unusual strain and is not considered normal use. This warranty does not cover consumables (e.g., fuses or batteries), other than the 90 day warranty as to the lamp. This warranty does not apply to used, refurbished or reconditioned products and is not transferable. The warranty does not cover set up adjustments or signal reception problems; it does not cover damage due to misuse, abuse or neglect or due to disasters such as fire, water or lightning, or due to electrical currents or surges; it does not cover failure to properly maintain the Product, improper shipping or installation, using the product other than as intended, interaction with non-Epson products, or service or modification of the Product other than by an Epson Authorized Servicer. The warranty shall be invalid if the Epson label, rating label or serial number has been altered or removed. If a claimed defect cannot be identified or reproduced in service, or you fail to make the Product available for a service call, you will be held responsible for costs incurred.

THIS WARRANTY AND REMEDY ARE EXCLUSIVE AND IN LIEU OF ALL OTHER EXPRESS OR IMPLIED WARRANTIES INCLUDING, BUT NOT LIMITED TO, THE IMPLIED WARRANTIES OF MERCHANTABILITY OR FITNESS FOR A PARTICULAR PURPOSE. SOME LAWS DO NOT ALLOW THE EXCLUSION OF IMPLIED WARRANTIES. IF THESE LAWS APPLY, THEN ALL EXPRESS AND IMPLIED WARRANTIES ARE LIMITED TO THE WARRANTY PERIOD IDENTIFIED ABOVE. UNLESS STATED HEREIN, ANY STATEMENTS OR REPRESENTATIONS MADE BY ANY OTHER PERSON OR FIRM ARE VOID. EXCEPT AS PROVIDED IN THIS WRITTEN WARRANTY, NEITHER EPSON AMERICA, INC. NOR ITS AFFILIATES SHALL BE LIABLE FOR ANY LOSS, INCONVENIENCE, OR DAMAGE, INCLUDING DIRECT, SPECIAL, INCIDENTAL OR CONSEQUENTIAL DAMAGES, RESULTING FROM THE USE OR INABILITY TO USE THE EPSON PRODUCT, OR FROM LOSS DATA, WHETHER RESULTING FROM BREACH OF WARRANTY OR ANY OTHER LEGAL THEORY. IF THE REMEDY ABOVE FAILS, EPSON'S ENTIRE LIABILITY SHALL BE LIMITED TO A REFUND OF THE PRICE PAID FOR THE EPSON PRODUCT COVERED BY THIS LIMITED WARRANTY.

In Canada, warranties include both warranties and conditions.

Some jurisdictions do not allow limitations on how long an implied warranty lasts, and some jurisdictions do not allow the exclusion or limitation of incidental or consequential damages, so the above limitations and exclusions may not apply to you. This warranty gives you specific legal rights, and you may also have other rights, which vary from jurisdiction to jurisdiction.

For warranty support, call the Epson ConnectionSM at (800) 637-7661 + PIN or (562) 276-4394 in the U.S. and (905) 709-3839 in Canada, or write to: Epson America, Inc., P.O. Box 93012, Long Beach, CA 90809-3012.



ENERGY STAR Compliance

As an ENERGY STAR Partner, Epson has determined that this product meets the ENERGY STAR guidelines for energy efficiency.

Note on Closed Captioning

This television receiver provides display of television closed captioning in accordance with §15.119 of the FCC rules.

Note on TV Use

Use of this television receiver for other than private viewing of programs broadcast on UHF or VHF, or transmitted by cable or satellite companies, for the use of the general public may require authorization from the broadcast/cable/satellite company and/or program owner.

FCC Compliance Statement

For United States Users

This equipment has been tested and found to comply with the limits for a Class B digital device, pursuant to Part 15 of the FCC Rules. These limits are designed to provide reasonable protection against harmful interference in a residential installation. This equipment generates, uses, and can radiate radio frequency energy and, if not installed and used in accordance with the instructions, may cause harmful interference to radio or television reception. However, there is no guarantee that interference will not occur in a particular installation. If this equipment does cause interference to radio and television reception, which can be determined by turning the equipment off and on, the user is encouraged to try to correct the interference by one or more of the following measures:

- Reorient or relocate the receiving antenna.
- Increase the separation between the equipment and receiver.
- Connect the equipment into an outlet on a circuit different from that to which the receiver is connected.
- Consult the dealer or an experienced radio/TV technician for help.

WARNING

The connection of a non-shielded equipment interface cable to this equipment will invalidate the FCC Certification of this device and may cause interference levels which exceed the limits established by the FCC for this equipment. It is the responsibility of the user to obtain and use a shielded equipment interface cable with this device. If this equipment has more than one interface connector, do not leave cables connected to unused interfaces. Changes or modifications not expressly approved by the manufacturer could void the user's authority to operate the equipment.

For Canadian Users

This Class B digital apparatus meets all requirements of the Canadian Interference-Causing Equipment Regulations.

Index

A

- Adding channels, 49
- Adjusting picture and sound, 63 to 68
- Air filter, cleaning, 95 to 96
- Antenna
 - connecting, 17
 - grounding, 10
 - satellite, 20
- Antenna 1/2 settings, 47 to 48, 73
- Aspect button, 66 to 67
- Aspect ratio
 - changing screen, 66 to 67
 - for frozen images, 71
- ATSC/NTSC tuner
 - connecting, 14
 - controlling with TV remote, 35
- Audio
 - default settings, 68
 - problems, 113
 - setting volume, 68
- Audio receiver, 29
- Audio track, selecting, 75
- Auto Program setting, 47 to 48
- Auto Shutdown setting, 76

B

- Balance setting, 68
- Bass setting, 68
- Batteries, remote control, 33, 114
- Black Level setting, 63 to 65
- Blocking
 - channels, 59 to 61
 - input sources, 59 to 61
 - programs, V-Chip, 55 to 59
- Brightness setting, 63 to 65

C

- Cable TV
 - cable box connection, 18 to 19
 - cable box/VCR connection, 26
 - direct cable/VCR connection, 25
 - direct connection, 17

Cables

- antenna, 17
 - audio receiver, 29
 - cable box, 18 to 19
 - cable box/VCR, 26
 - camcorder, 31
 - component video, *see* Component video
 - connecting, 14 to 32
 - direct cable TV, 17
 - direct cable/VCR, 25
 - DVI-HDTV, 21
 - game console, 30
 - headphone, 32
 - PC, 30
 - remote IR repeater, 32
 - satellite receiver/VCR, 27 to 28
 - standard video, *see* Standard video
 - S-Video, *see* S-Video
 - USB, 15
- Camcorder, 31
- Cancelling
 - CD-R/RW writing, 94
 - print jobs, 91 to 92
- Captions, displaying, 75
- Capture Method setting, 71
- Card light, 78, 79, 84, 89, 93, 111
- Card, photo, *see* Digital photo card
- Caring for TV, 95 to 107
- Cassette
 - paper, 87 to 89
 - printer ink, 101, 103 to 106
- CD
 - cancelling writing to, 94
 - ejecting, 82, 94
 - file structure, 80
 - folders, 82
 - inserting in drive, 80 to 81
 - printing photos on, 86 to 92
 - problems, 115
 - saving photos on, 92 to 94, 121
 - slide show, 84 to 85
 - viewing photos on, 80 to 82
- CD-R/RW drive
 - cable connection, 15
 - inserting CD in, 80 to 82
- Channel zapping, 55, 73 to 74

Channel(s)
 adding, 49
 Auto Program setting, 47 to 48
 blocking, 59 to 61
 buttons, 50
 favorite, 50
 labelling, 51 to 52
 Lock setting, 59 to 61
 Manual Program setting, 49
 menu, 51 to 52, 73
 problems, 114
 selecting, 50
 setting up, 47 to 49
 skipping, 49
 specifications, 123
 zapping, 55, 73 to 74

Cleaning
 air filter, 95 to 96
 TV, 95

Closed Caption setting, 75, 128

Codes, remote control programming, 36 to 40

Color Mode
 setting, default, 63 to 65

Color Temp. setting, 63 to 65

Component video
 digital receiver connection, 14 to 15
 DVD player connection, 22

Contrast setting, 63 to 65

Copies setting, 70, 90

Cover
 lamp, 99 to 101
 speaker, 98, 101

Cropping photos for printing, 83

D

DCF format, 77

Digital photo card
 file structure, 77 to 78
 inserting, 78 to 79
 printing photos on, 86 to 92
 problems, 115
 saving photos on CD, 92 to 94
 slide show, 84 to 85
 viewing photos on, 77 to 79

Digital receiver
 component video connection, 14 to 15

Display size
 changing, 66 to 67
 specifications, 123

Display type
 setting default, 63 to 65

Drive, *see* CD-R/RW drive

DVD player
 component video connection, 22
 DVI-HDTV connection, 21
 progressive scan, 71
 S-Video connection, 23

DVI-HDTV
 cable connection, 21
 port, skipping unused, 43

E

Ejecting CD, 82, 94

Electrical specifications, 123

ENERGY STAR, 128

Enlarging
 photos, 83
 screen display, 66 to 67

Epson
 contacting, 121
 supplies and accessories, 121

Epson Store, 121

Equipment switch, 36, 114

Error messages, 90, 109

F

Favorite channels, 50

FCC statement, 129

Features, using TV, 69 to 76

Filter, cleaning, 95 to 96

Folders, CD, 82

Freeze button, 69

Freezing images
 aspect ratio, 71
 capture settings, 71
 monitoring printing, 91 to 92
 on screen, 69 to 70
 printing, 69 to 70

G

Game
 blocking console port, 59 to 61
 console cable connection, 30

Grounding, antenna, 10

H

Headphones
 cable connection, 32
 volume, 68

Help, 121

I

- Ink cassette
 - problems, 115 to 116
 - replacing, 101 to 106
- Input source
 - blocking, 59 to 61
 - labelling, 44 to 45
 - skipping unused, 43
- Interface specifications, 124

J

- Jammed paper, clearing, 116 to 120
- JPEG format, 77, 80
- Jumper cable, 73

L

- Labelling
 - channels, 51 to 52
 - input sources, 44 to 45
- Lamp
 - cover, 99 to 101
 - light, 97, 101, 110 to 111
 - messages, 97
 - part number, 98
 - problems, 109 to 111
 - replacing, 97 to 101
 - specifications, 123
- Language setting, 42 to 43
- Letterbox format, 66 to 67
- Lights, 110 to 111, 114
- Loading paper, 86 to 89
- Location, selecting, 7 to 11
- Lock
 - menu, 53 to 61
 - printer, 102, 106, 117 to 118, 120
 - setting, 59 to 61

M

- Maintaining TV, 95 to 107
- Manual Program setting, 49
- Mechanical specifications, 123
- Memory card, *see* Digital photo card
- Menu language, 42 to 43
- Monitoring print jobs, 91
- Moving TV, 107
- MTS setting, 75
- Mute button, 68

N

- No Signal message, 41 to 42

P

- Paper
 - cassette, 86 to 89
 - jams, clearing, 116 to 120
 - loading, 86 to 89
- Parental controls
 - channel blocking, 59 to 61
 - input source blocking, 59 to 61
 - password, *see* Password
 - ratings, 58 to 59
 - setting up, 53 to 61
 - V-Chip blocking, 55 to 59
- Password
 - accessing TV with, 61 to 62
 - changing, 53 to 54
 - creating, 53 to 54
 - entering, 55
 - problems, 112
- PC
 - cable connection, 30
 - port, skipping unused, 43
- Photo card, *see* Digital photo card
- Photo View button, 79, 81, 84, 89
- Photo Zoom buttons, 72
- Photo(s)
 - cropping for printing, 83
 - enlarging, 83
 - on CD, 80 to 82
 - on photo card, 77 to 79
 - printing, 86 to 92
 - problems, 115
 - rotating, 83
 - saving, 92 to 94
 - slide show, 84 to 85
 - viewing, 77 to 85, 94
- Picture quality
 - adjusting, 63 to 65
 - problems, 112 to 113
- Picture-Outside-Picture (POP), 71 to 72, 74
- Playback setting, 85
- POP button, 72, 74
- Position setting, 63 to 65
- Power
 - button, 41 to 42, 46
 - light, 41, 46, 76, 78, 80, 97, 101, 110 to 111
 - specifications, 123
 - turning off, 46
 - turning on, 41 to 42
- Precautions, 7 to 10
- Print button, 70, 90

Printer

- light, 70, 90, 111
- lock, 102, 106, 117 to 118, 120
- paper, *see* Paper
- replacing ink, 101 to 106
- sliding in, 106
- sliding out, 101 to 103, 117 to 118
- specifications, 125
- using, *see* Printing

Printer light, 78

Printing

- cancelling, 91 to 92
- error messages, 90
- frozen images, 69 to 70
- loading paper, 86 to 89
- monitoring jobs, 91
- photos, 86 to 92
- problems, 115 to 120

Problems

- audio, 113
- basic operation, 112
- CD, 115
- channel, 114
- error messages, 109
- lamp, 110 to 111
- light indicators, 110 to 111
- password, 112
- picture quality, 112 to 113
- printing, 115 to 120
- remote control, 114
- saving to CD-R/RW, 121
- sound, 113
- TV, 109 to 114
- viewing photos, 115

Program blocking, V-Chip, 55 to 59

Progressive scan DVD player, 71

Projection lamp, *see* Lamp

R

Ratings, V-Chip, 58 to 59

Reception, TV, 114

Remote control

- ATSC tuner code, 36
- batteries, inserting, 33
- controlling other equipment, 36 to 40
- equipment switch, 36, 114
- information, 34
- light, 114
- operating, 34
- preparing, 33 to 34
- problems, 114

Remote control (*continued*)

- programming, 36 to 40
- using with other equipment, 36

Remote IR repeater, 32

Rotate button, 83, 89

S

Safety instructions, 7 to 10

Satellite receiver

- S-Video connection, 20
- VCR connection, 27 to 28

Saturation setting, 63 to 65

Saving photos to CD-R/RW, 92 to 94, 121

Screen

- aspect ratio, 66 to 67
- cleaning, 95
- display size, setting, 66 to 67
- error messages, 90, 109
- freezing images, *see* Freezing images
- picture quality, 63 to 65
- position setting, 63 to 65
- problems, 112 to 113

Setting up the TV, 7 to 46

Sharpness setting, 63 to 65

Shelf, set-top, 12

Shipping TV, 107

Shutting off TV automatically, 76

Skipping

- channels, 49
- unused input sources, 43

Sleep button, 76

Slide show

- changing settings for, 85
- selecting photos for, 84 to 85
- viewing, 84 to 85

Sound

- adjusting, 68
- problems, 113

Speaker

- cover, 98, 101
- setting, 68
- specifications, 123
- volume setting, 68

Specifications, 123 to 125

Standard video
 camcorder connection, 31
 DVD player connection, 23
 satellite receiver connection, 20
 VCR connection, 24
 VCR/cable box connection, 26
 VCR/direct cable connection, 25
 VCR/satellite receiver connection, 27 to 28

Stands/supports, TV, 11, 107

Surround setting, 68

S-Video
 camcorder connection, 31
 DVD player connection, 23
 satellite receiver connection, 20
 VCR connection, 24
 VCR/cable box connection, 26
 VCR/direct cable connection, 25
 VCR/satellite receiver connection, 27 to 28

Swap button, 72, 74

T

Temperature
 problems, 109 to 111
 specifications, 124

TIF format, 78, 80

Tint setting, 63 to 65

Transition speed setting, 85

Transporting TV, 107

Treble setting, 68

Troubleshooting, 109 to 121

Tuner, ATSC/NTSC
 controlling with TV remote, 35

Turning off system, 46, 76

Turning on system, 41 to 42

TV
 adjusting picture and sound, 63 to 68
 air filter, cleaning, 95 to 96
 caring for, 95 to 107
 cleaning, 95
 connecting cables, 14 to 32
 dimensions, 123
 error messages, 90, 109
 features, using, 69 to 76
 lamp, *see* Lamp
 menus, *see* Menu system
 moving, 107
 printer, *see* Printer
 problems, 109 to 114
 reception, 114
 remote control, *see* Remote control
 screen, *see* Screen

TV (*continued*)
 selecting location, 7 to 11
 setting up, 7 to 46
 shelf, 12
 shipping, 107
 shutting off automatically, 76
 sleep mode, 76
 stands, 11, 107
 supports, 11, 107
 transporting, 107
 turning off, 46
 turning on, 41 to 42
 usage notification, 128
 weight, 123

TV/Video button, 41 to 42, 71

U

USB/CD-R/RW drive connection, 15

V

V-Chip blocking, 55 to 59

VCR
 standard video connection, 24
 standard video/cable box connection, 26
 standard video/direct cable connection, 25
 standard video/satellite connection, 27 to 28
 S-Video connection, 24
 S-Video/cable box connection, 26
 S-Video/direct cable connection, 25
 S-Video/satellite receiver connection, 27 to 28

Viewing
 photos, 77 to 85, 94

Volume, 68

W

Weight, TV, 123

Where To Get Help, 121

Writing photos to CD-R/RW, 92 to 94

Z

Zapping channels, 55, 73 to 74

